

Messing M

Verschraubungen

Laiton M

Raccords

Brass M

Unions



KOVALAN S.r.l.

Seite/Page/Page

Seite/Page/Page

Seite/Page/Page

Klemmring
Bague de serrage
Compression ferrule

4M.4-4M.7



SO 40001

Schlauchtülle
Douille cannelée
Hose nozzle

4M.22-4M.23



SO 40503

Gerade Schottverschraubung reduziert
Union double réduite pour passage de cloison
Panel mount reduction union

4M.40-4M.43



SO 41521

Abschlusszapfen
Bouchon d'arrêt
Plug

4M.8



SO 40002

Anschlussnippel
Ecrou de raccordement mâle
Nipple connection

4M.24



SO 41001

Einstellnippel
Union orientable mâle
Adjustable male adaptor

4M.44-4M.47



SO 41600

Stützhülse
Douille d'appui
Stiffener sleeve

4M.9-4M.11



SO 40003

Gerade Verschraubung
Union double
Straight union

4M.25-4M.26



SO 41021

Einstellmuffe
Union orientable femelle
Adjustable female adaptor

4M.48-4M.49



SO 41704

Dichtung
Joint
Washer

4M.12-4M.14



SO 40005

Gerade Einschraubverschraubung
Union mâle
Male adaptor union

4M.27-4M.33



SO 41121

Reduktionsverschraubung
Réduction
Reduced union

4M.50



SO 41821

Anschlussmutter
Ecrou
Union nut

4M.15



SO 40020

Gerade Aufschraubverschraubung
Union femelle
Female adaptor union

4M.34-4M.35



SO 41221

Winkelverschraubung
Coude
Elbow union

4M.51-4M.54



SO 42021

Armaturenanschluss
Ecrou de raccordement
Nut connection

4M.16-4M.18



SO 40021

Verbindungsnippel
Pièce folle
Tube stub

4M.36-4M.37



SO 41300 / SO 41304

Anschlusswinkel
Coude femelle
Female adaptor elbow union

4M.55



SO 42321

Übergangsmuffe
Adapteur femelle
Female adaptor

4M.19



SO 40030

Einstellbare Kupplung
Accouplement orientable
Adjustable coupling

4M.38



SO 41325

Einschraubwinkel
Coude mâle
Male adaptor elbow union

4M.56-4M.58



SO 42421

Übergangsnippel
Pièce intermédiaire mâle
Male adaptor

4M.20-4M.21



SO 40040

Verschraubung mit Einlötnippel
Union avec embout à braser
Adaptor union with soldering nipple

4M.39



SO 41421

Winkel-Aufschraubverschraubung
Coude femelle
Female adaptor elbow union

4M.59



SO 42521

Seite/Page/Page

Seite/Page/Page

Seite/Page/Page

Einstellwinkel
Coude orientable
Adjustable elbow union

4M.60-4M.61



SO 42621

Schwenkverschraubung
Coude banjo
Single banjo

4M.81-4M.82



SO 47624

Reduziermuffe
Manchon de réduction
Female reduction muff

4M.90-4M.91



SO 40031

Winkel-Schottverschraubung
Coude pour passage de cloison
Panel mount elbow union

4M.62-4M.63



SO 42721

Rohnippel
Mamelon
Double nipple

4M.86



AD CNS 40

Reduziernippel
Réduction femelle-mâle
Male reduction nipple

4M.92-4M.94



SO 40041

Schwenkverschraubung
Coude banjo
Single banjo

4M.64-4M.66



SO 42824

Aufschraub-Winkel
Coude double femelle
Female elbow

4M.86



AD FE 40

Einschraubtülle
Douille canelée à visser
Male adaptor hose nipple

4M.94



SO 40511

T-Verschraubung
Té
Tee union

4M.67-4M.73



SO 43021

Aufschraub-T
Té triple femelle
Female tee

4M.86



AD FT 40

**Sonderausführungen:
Exécution en option:
Optional Services:**



Spezialbehandlung für Einsatz mit Sauerstoff
Traitement spécial pour utilisation sous oxygène
Special treatment for use with oxygen



Spezialbehandlung - silikongfrei
Traitement spécial - sans silicone
Special treatment - silicone free



Spezialreinigung - entfettet
Traitement spécial - sans silicone
Special treatment - degreased



Vorbeschichtete Gewinde mit Loctite 5061
Filetages pré enduits avec Loctite 5061
Pre-coated threads with Loctite 5061



Vorbeschichtete Gewinde PTFE-Band umwickelt
Filetages pré enduits avec ruban en PTFE
Pre-coated threads with PTFE-tape



Chemisch vernickelt
Nickelage chimique
Chemical nickel-plated



Messing bleifrei
Laiton sans plomb
Unleaded brass

Einstell-T und L
Té et L orientable
Adjustable tee and L union

4M.74-4M.75



SO 43621

Sechskant-Muffe
Manchon double
Hex coupling

4M.87



AD HC 40

T- und L-Einschraubverschraubung
Té et L mâle
Male adaptor tee and L union

4M.76-4M.77



SO 43721

Rohrkappe
Capuchon femelle
Hex cap

4M.87



AD HCP 40

T-Schwenkverschraubung
Té banjo
Tee banjo

4M.78-4M.79



SO 43824

Doppelnippel
Adaptateur mâle
Male adaptor

4M.88



AD HN 40

Kreuzverschraubung
Croix
Cross union

4M.80



SO 44021

Verschlusschraube mit O-Ring
Bouchon d'obturation avec joint torique
Screw plug with O-Ring

4M.89-4M.90



AD HPO 40

Sonderausführung für Adapter
siehe Kapitel 9

Exécution en option pour adaptateurs
voir chapitre 9

Option services for adaptors
see chapter 9

Messing M

Eigenschaften, Besonderheiten

- einfache, schnelle Montage
- kompakte Baumassee
- grosse Sortimentsvielfalt
- sehr viele Kombinationsmöglichkeiten
- zwei Ausführungen:
M = Anschlussmutter metrisch
G = Anschlussmutter Rohrgewinde (Zoll)
(M und G nicht austauschbar)

Funktionsprinzip

siehe Anhang

Werkstoff

Messing CuZn40Pb2 (CW 617N). Oberfläche gebeizt.
Chemisch vernickelt, siehe Kapitel 8.

Nenndruck PN

siehe Produktetabellen (4fache Sicherheit).
Dynamische Belastungen auf Anfrage.

Temperaturbereich

-40°C bis +180°C.

Vakuum

Bis 10⁻⁴mbar, höhere Werte möglich.

Anzusschliessende Rohre

Kunststoffrohre und nahtlose, gezogene Kupferrohre (insbes. EN 12449/1057) mit sauberer, glatter Oberfläche. Aussendurchmesser innerhalb ± 0,1 mm. Siehe auch Kapitel Rohre und Schläuche. Weitere Materialien auf Anfrage.

Zulassungen

SVGW, DVGW und ÖVGW

Einschraubzapfen, Gewinde

Rohrgewinde (Zoll) und metrisches Feingewinde DIN 3852, kegelig Form C, zylindrisch Form B, mit Dichtkante Form E. NPT-Gewinde nach ANSI/ASME B1.20.1-1983.

Druckauswertungsgrad in % des PN

Laiton M

Généralités

- montage facile et rapide
- compactes dimensions
- programme étendu
- multiples possibilités de combinaisons
- deux exécutions:
M = Ecou SERTO avec filetage métrique
G = Ecou SERTO avec filetage (BSP) gaz
(M et G ne sont pas interchangeables)

Principe de fonctionnement

voir annexe

Matériau

Laiton CuZn40Pb2 (CW 617N). La surface est décapée.
Nickelée par voie chimique, voir chapitre 8.

Pression nominale PN

voir tableaux des produits (facteur de sécurité 4). Sollicitations dynamique sur demande.

Plage de température admissible

-40°C à +180°C.

Vide

Jusqu'à 10⁻⁴mbar, plus poussé possible.

Tubes à utiliser

Tubes en matière plastique et tous les tubes en cuivre sans soudure (selon EN 12449/1057) avec surface propre et lisse. Le diamètre extérieur doit être situé dans une tolérance de ± 0,1 mm. Voir chapitre tubes et tuyaux. Autres matériaux sur demande.

Homologations

SSIGE, DVGW et ÖVGW

Embouts mâles, filetages

Filetage gaz (BSP) et filetage métrique à pas fin DIN 3852. Conique selon forme C. Cylindrique selon forme B. Filetage d'étanchéité selon forme E. Filetage NPT selon ANSI/ASME B1.20.1-1983.

Coefficient de pression de service admissible en % de PN

Brass M

Characteristics, specialities

- easy and fast to install
- compact size
- extensive range
- many combination possibilities
- two models:
M = Connection nut with metric thread
G = Connection nut with British Standard Pipe (BSP) thread
(M and G are not interchangeable)

Operating principle

see appendix

Material

Brass CuZn40Pb2 (CW 617N). The surface is pickled.
Chemically nickel plated, see chapter 8.

Nominal pressure PN

see product table (safety factor 4). Dynamic loads on demand.

Temperature range

-40°C to +180°C.

Vacuum

Up to 10⁻⁴mbar, higher values are possible.

Tubes to use

Tubes of plastic and seamless copper tubes (esp. EN 12449/1057) with clean smooth surface. Outside diameter of ± 0,1 mm. See also chapter tubes and hoses. Further materials on demand.

Approvals

SVGW, DVGW and ÖVGW

Adaptor stem, male thread

British Standard Pipe (BSP) and metric fine thread DIN 3852. Tapered form C, parallel form B. Thread with sealing form E. BSP-thread according to ANSI/ASME B1.20.1-1983.

Pressure coefficient % of PN

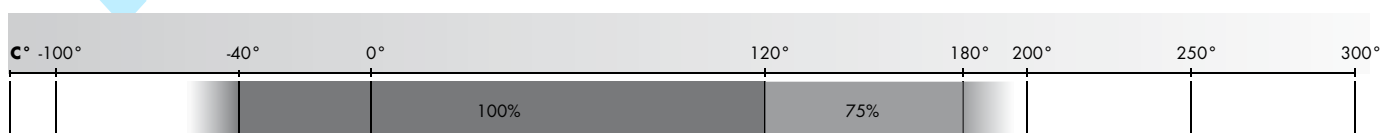

Klemmring

Bague de serrage

Compression ferrule

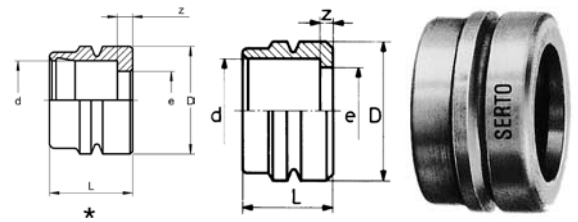

SO 40001

Type-d	Mat.-Nr.	bar	D	L	z	e	kg/100	
Für metrische Rohre	Pour tubes métriques	For metric tubes						
SO 40001-2	016.0010.020	125	3.6	3.5	0.6	1.5	0.015	
SO 40001-3	016.0010.030	125	5.0	4.5	0.8	2.5	0.030	
SO 40001-4	016.0010.040	125	6.0	5.0	1.0	3.5	0.060	
SO 40001-5	016.0010.050	125	6.8	5.5	1.0	4.0	0.060	
SO 40001-6 *	016.0010.060	250	8.4	6.5	1.2	4.5	0.120	
SO 40001-8 *	016.0010.080	150	10.5	7.0	1.2	6.5	0.170	
SO 40001-10 *	016.0010.100	125	12.7	7.8	1.2	8.5	0.250	
SO 40001-12 *	016.0010.120	100	14.7	8.8	1.2	10.0	0.330	
SO 40001-14	016.0010.140	40	17.5	10.0	1.4	12.0	0.510	
SO 40001-15	016.0010.150	40	18.0	10.0	1.4	13.0	0.510	
SO 40001-16	016.0010.160	40	21.0	11.7	1.4	14.0	0.510	
SO 40001-17	016.0010.170	40	21.0	11.7	1.4	15.0	0.850	
SO 40001-18	016.0010.180	40	22.0	11.7	1.4	16.0	0.910	
SO 40001-22	016.0010.220	25	26.0	13.0	1.4	20.0	1.270	
SO 40001-28	016.0010.280	16	32.5	15.4	2.0	24.0	2.140	
SO 40001-35	016.0010.350	16	39.5	17.0	2.0	32.5	3.000	
Für Zollrohre	Pour tubes pouces	For inch tubes						
SO 40001-3,2	016.0010.032	125	5.0	4.5	0.8	2.5	0.030	
SO 40001-6,35	016.0010.063	100	8.4	6.5	1.2	4.5	0.120	
SO 40001-7,94	016.0010.079	150	10.5	7.0	1.2	6.5	0.170	
SO 40001-9,52	016.0010.095	64	12.0	7.8	1.2	8.0	0.220	
SO 40001-15.88	016.0010.158	40	21.0	11.7	1.4	14.0	0.510	
SO 40001-22.22	016.0010.222	25	26.0	13.5	1.4	20.0	1.280	

4M

Klemmring

für Messleitungen

Bague de serrage

pour conduites de mesure

Compression ferrule

for gauge lines

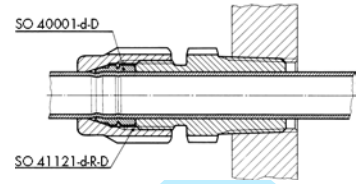

SO 40001 D

Type -d	Mat.-Nr.	L	D	kg/100
Für metrische Rohre	Pour tubes métriques		For metric tubes	
SO 40001-4 D	016.0012.040	5.0	6.0	0.050
SO 40001-6 D	016.0012.060	6.5	8.5	0.100
SO 40001-8 D	016.0012.080	7.0	10.5	0.150
SO 40001-10 D	016.0012.100	8.0	12.5	0.220
SO 40001-4-3,2 D	016.0012.042	7.0	6.0	0.750
SO 40001-6-4 D	016.0012.110	8.5	6.0	0.220
SO 40001-8-6 D	016.0012.188	9.5	10.5	0.280
SO 40001-10-8 D	016.0012.190	11.5	12.5	0.340

Klemmringe ohne Innenbund, durch die Rohre durchgesteckt werden können, sind auch lieferbar. Abmessungen wie Klemmring SO 40001.

Die Typen Nr. ist dann mit «D» zu ergänzen, z. B. SO 40001-d-D.

Komplette Verschraubungen für Messleitungen sind auch lieferbar. Die Typen Nr. ist dann zusätzlich mit «D» zu ergänzen, z. B. SO 41121-8 1/4 D.

Des bagues de serrage spéciales sans butée intérieure sont également livrables, permettant le libre positionnement du tube. Dimensions identiques aux bagues SO 40001.

Le numéro de type est alors à compléter de «D», p. ex. SO 40001 - d - D.

Des unions complètes pour conduites de mesure sont également livrables. Le numéro de type est alors à compléter de «D» p. ex. SO 41121 - 8 1/4 D.

Compression ferrules without inside shoulder, through which the tubing can be passed completely, e.g. gauge lines can also be supplied. Dimensions analogous to compression ferrule SO 40001.

Order-No. has to be supplemented with «D», e.g. type SO 40001 - d - D.

Complete unions for gauge lines can also be supplied. Order-No. for complete union has to be supplemented with «D»; e.g. type SO 41121 - 8 1/4 D.

Klemmring reduziert

Bague de serrage de réduction

Reduction compression ferrule

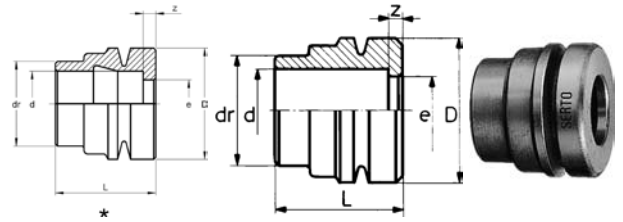

SO 40001 RED

Type-dr-d	Mat.-Nr.	L	bar	D	dr	z	e	kg/100
Für metrische Rohre	Pour tubes métriques			For metric tubes				
SO 40001-5-3 RED	016.0014.060	7.5	125	6.8	5.00	0.8	2.5	0.130
SO 40001-6-4 RED	016.0014.110	8.5	100	8.5	6.00	1.0	3.5	0.230
SO 40001-6-5 RED	016.0014.117	8.7	100	8.5	6.00	1.0	4.0	0.180
SO 40001-8-6 RED *	016.0014.140	9.5	250	10.5	8.00	1.2	4.5	0.330
SO 40001-10-8 RED *	016.0014.190	11.5	150	12.7	10.00	1.2	6.5	0.450
SO 40001-12-10 RED *	016.0014.240	12.5	100	14.7	12.00	1.2	8.5	0.610
SO 40001-14-12 RED	016.0014.340	14.0	40	17.5	14.00	1.4	10.0	0.890
SO 40001-15-12 RED	016.0014.420	14.0	40	18.0	15.00	1.4	10.0	1.050
SO 40001-15-13 RED	016.0014.430	14.0	40	18.0	15.00	1.4	11.0	3.030
SO 40001-17-14 RED	016.0014.530	15.7	40	21.0	17.00	1.4	12.0	1.560
SO 40001-18-15 RED	016.0014.610	15.7	40	22.0	18.00	1.4	13.0	1.660
SO 40001-18-16 RED	016.0014.620	15.7	40	22.0	18.00	1.4	14.0	1.430
SO 40001-22-17 RED	016.0014.750	19.0	25	26.0	22.00	1.4	15.0	3.030
SO 40001-22-18 RED	016.0014.755	19.0	25	26.0	22.00	1.4	16.0	2.850
SO 40001-22-19 RED	016.0014.760	19.0	25	26.0	22.00	1.4	17.0	2.600

Für Zollrohre	Pour tubes pouces			For inch tubes				
SO 40001-4-3.2 RED	016.0014.042	125	7.0	6.0	4.00	0.8	2.5	0.090
SO 40001-10-7,94 RED	016.0014.187	150	11.5	12.7	10.00	1.2	6.5	0.450
SO 40001-15-12,7 RED	016.0014.427	40	14.0	18.0	15.00	1.4	11.0	3.030
SO 40001-22-19,05 RED	016.0014.762	25	19.0	26.0	22.00	1.4	17.0	2.600

4M

Anwendungsbeispiele:

Exemples d'utilisation:

Sample combinations:

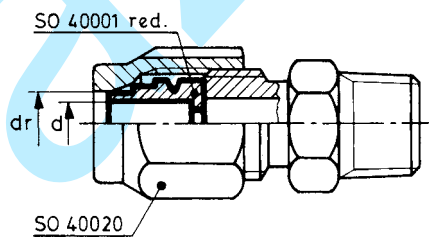

Einstufige Reduktionen von Rohranschlüssen sind auf einfachste Art durch Auswechseln der normalen gegen die reduzierten Klemmringe möglich.

Beispiel:
Reduktion eines Rohranschlusses $\varnothing 15\text{mm}$ auf $\varnothing 12\text{mm}$: Klemmring SO 40001-15 austauschen gegen Klemmring SO 40001-15-12 RED. Anschlussmutter SO 40020-15 bleibt.

Le raccordement de tubes réduits d'une dimension peut s'effectuer très simplement en échangeant la bague de serrage normale contre une bague de réduction.

Exemple:
Réduction d'un raccord $\varnothing 15\text{mm}$ à $\varnothing 12\text{mm}$: Echanger la bague de serrage SO 40001-15 contre une bague de réduction SO 40001-15-12 RED. L'écrou SO 40020-15 reste le même.

Single stage tube reduction connections are easily made by replacing the standard compression ferrule with a reduction compression ferrule.

Example:
Tube reduction connection $\varnothing 15\text{mm}$ to $\varnothing 12\text{mm}$: Replace compression ferrule SO 40001-15 by compression ferrule SO 40001-15-12 RED. Union nut SO 40020-15 remains.

Messing M

Laiton M

Brass M

Klemmring

mit fixierter Stützhülse

Bague de serrage

avec douille d'appui fixée

Compression ferrule

with fixed stiffener sleeve

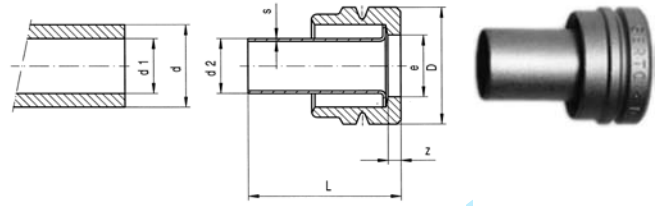

SO 40001 FIX

Type -d-d1	Mat.-Nr.	bar	L	D	s	z	e
SO 40001-6-4 FIX	016.0015.110	100	11.0	8.5	0.20	1.0	4.5
SO 40001-8-6 FIX	016.0015.140	100	13.0	10.5	0.25	1.0	6.5

KOVANZ S.r.l.

Abschlusszapfen
Bouchon d'arrêt
Plug

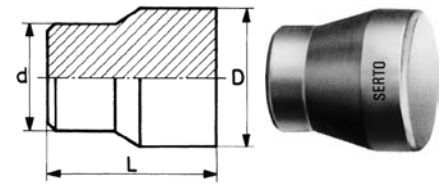

SO 40002

SO 40002

Type -d	Mat.-Nr.	L	D	kg/100
Für metrische Rohre	Pour tubes métriques		For metric tubes	
SO 40002-2	016.0020.020	5.3	5.0	0.040
SO 40002-3	016.0020.030	7.0	5.0	0.080
SO 40002-4	016.0020.040	8.0	6.8	0.150
SO 40002-5	016.0020.050	8.5	6.8	0.190
SO 40002-6	016.0020.060	10.0	8.4	0.310
SO 40002-8	016.0020.080	10.5	10.5	0.570
SO 40002-10	016.0020.100	13.0	12.7	0.960
SO 40002-12	016.0020.120	14.0	14.8	1.470
SO 40002-14	016.0020.140	15.0	17.5	2.230
SO 40002-15	016.0020.150	15.0	18.0	2.370
SO 40002-17	016.0020.170	17.2	21.0	3.680
SO 40002-18	016.0020.180	16.8	22.0	4.000
SO 40002-22	016.0020.220	19.0	26.0	6.300
SO 40002-28	016.0020.280	22.5	32.5	11.900
SO 40002-35	016.0020.350	25.2	39.5	20.000

Für Zollrohre	Pour tubes pouces		For inch tubes	
SO 40002-6,35	016.0020.063	10.0	8.4	0.310
SO 40002-7,94	016.0020.079	10.5	10.5	0.570
SO 40002-9,52	016.0020.095	13.0	12.7	0.960
SO 40002-12,7	016.0020.127	15.0	17.5	2.230

4M

Anwendungsbeispiele:

Exemples d'utilisation:

Sample combinations:

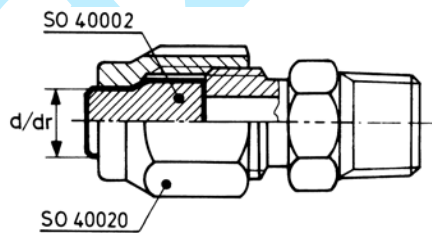

Werkstoff: Messing

Matériau: Laiton

Material: Brass

Der Abschlusszapfen lässt sich in jede Verschraubung anstelle eines Klemmringes gleicher Größe d einsetzen.

Le bouchon d'arrêt peut remplacer la bague de serrage de même dimension d dans chaque raccord.

The plug can be fitted into any union in place of a compression ferrule of same diameter d.

Anschlussmutter mit 1/4 Drehung anziehen.

Serrer l'écrou avec 1/4 tour.

Tighten the union nut with 1/4 turn.

Stützhülse

zur Rohrverstärkung

Douille d'appui

pour renforcer les tubes

Stiffener sleeve

to reinforce the tubes

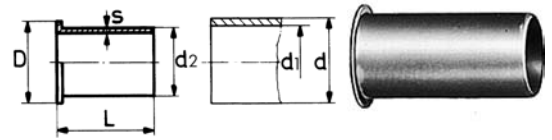

SO 40003

Type - d - d1	Mat.-Nr.	L	D	d2	s	kg/100
Für metrische Rohre	Pour tubes métriques					
SO 40003-3-2	016.0030.020	6.0	2.8	1.9	0.20	0.006
SO 40003-3-2,4	016.0030.024	6.0	2.8	2.3	0.20	0.007
SO 40003-4-2	016.0030.030	8.0	3.8	1.9	0.20	0.008
SO 40003-4-2,5	016.0030.035	8.0	3.8	2.4	0.20	0.010
SO 40003-4-3	016.0030.040	8.0	3.8	2.9	0.20	0.010
SO 40003-5-3	016.0030.060	8.0	4.5	2.9	0.20	0.015
SO 40003-5-3,5	016.0030.075	8.0	4.5	3.4	0.20	0.020
SO 40003-6-3	016.0030.100	10.0	5.2	2.9	0.20	0.015
SO 40003-6-4	016.0030.110	10.0	5.5	3.9	0.20	0.025
SO 40003-6-4,4	016.0030.113	10.0	5.5	4.3	0.20	0.025
SO 40003-6-4,65	016.0030.116	10.0	5.5	4.6	0.20	0.025
SO 40003-6-4,7 D	016.0030.118	10.0	5.5	4.6	0.40	0.046
SO 40003-8-5	016.0030.136	12.0	7.5	4.9	0.25	0.040
SO 40003-8-5,5	016.0030.138	12.0	7.5	5.4	0.25	0.045
SO 40003-8-6	016.0030.140	12.0	7.5	5.9	0.25	0.045
SO 40003-8-6,4	016.0030.144	12.0	7.5	6.3	0.25	0.050
SO 40003-10-7	016.0030.180	16.0	9.5	6.9	0.30	0.080
SO 40003-10-7,5	016.0030.185	16.0	9.5	7.4	0.30	0.090
SO 40003-10-8	016.0030.190	16.0	9.5	7.8	0.30	0.100
SO 40003-10-8 D	016.0030.189	16.0	9.5	7.8	0.60	0.190
SO 40003-10-8,4	016.0030.192	16.0	9.5	8.3	0.30	0.095
SO 40003-10-8,6	016.0030.193	16.0	9.5	8.5	0.30	0.095
SO 40003-12-9	016.0030.230	20.0	11.5	8.8	0.40	0.190
SO 40003-12-9,5	016.0030.235	20.0	11.5	9.4	0.40	0.195
SO 40003-12-10	016.0030.240	20.0	11.5	9.8	0.40	0.195
SO 40003-12-10.4	016.0030.254	20.0	11.5	10.2	0.40	0.195
SO 40003-12-11 D	016.0030.257	20.0	12.0	10.8	1.00	0.500
SO 40003-13-11	016.0030.280	20.0	12.5	10.8	0.50	0.330
SO 40003-13-11 D	016.0030.279	20.0	12.5	10.8	1.00	0.530
SO 40003-14-11	016.0030.330	24.0	13.5	10.8	0.50	0.350
SO 40003-14-11,5	016.0030.335	24.0	13.5	11.4	0.50	0.350
SO 40003-14-12	016.0030.340	24.0	13.5	11.8	0.50	0.370
SO 40003-15-12,5	016.0030.425	24.0	14.5	12.4	0.50	0.390
SO 40003-15-13	016.0030.430	24.0	14.5	12.8	0.50	0.390
SO 40003-16-13,5	016.0030.495	26.0	15.5	13.4	0.50	0.430
SO 40003-16-14	016.0030.500	26.0	15.5	13.8	0.50	0.470
SO 40003-16-14 D	016.0030.499	26.0	15.5	13.8	0.10	0.900
SO 40003-17-15	016.0030.540	26.0	16.5	14.7	0.60	0.590
SO 40003-18-15	016.0030.610	26.0	16.5	14.7	0.60	0.590
SO 40003-18-15,6	016.0030.616	26.0	17.5	15.3	0.60	0.610
SO 40003-18-16	016.0030.620	26.0	17.5	15.7	0.60	0.630
SO 40003-19-17	016.0030.640	28.0	18.5	16.7	0.60	0.820

Fortsetzung nächste Seite

Suite à la prochaine page

Continued on next page

d=Rohrussen-ø
d1=Rohrinnen-ø
s=Rohrwandstärke

d=ø extérieur du tube
d1=ø intérieur de tube
s=épaisseur de la paroi du tube

d=tube outside diameter
d1=tube inside diameter
s=tube wall thickness

Stützhülse

zur Rohrverstärkung

Douille d'appui

pour renforcer les tubes

Stiffener sleeve

to reinforce the tubes

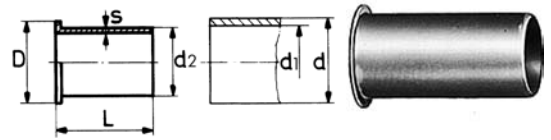

SO 40003

Type -d-d1	Mat.-Nr.	L	D	d2	s	kg/100	
Für metrische Rohre	Pour tubes métriques	For metric tubes					
SO 40003-20-17	016.0030.690	28.0	19.5	16.7	0.60	0.800	
SO 40003-20-18	016.0030.700	28.0	19.5	17.7	0.60	0.830	
SO 40003-22-19	016.0030.760	30.0	21.5	18.7	0.60	0.850	
SO 40003-22-19,6	016.0030.771	30.0	21.5	19.3	0.60	0.940	
SO 40003-22-20	016.0030.775	30.0	21.5	19.7	0.60	0.980	
SO 40003-28-25	016.0030.870	36.0	27.5	24.7	0.80	1.500	
SO 40003-28-25,6	016.0030.876	36.0	27.5	25.3	0.80	1.600	
SO 40003-35-32	016.0030.890	41.0	34.0	31.7	0.85	2.500	
Für Zollrohre	Pour tubes pouces	For inch tubes					
SO 40003-6,35-4,3	016.0030.112	10.0	5.5	4.3	0.20	0.023	
SO 40003-9,52-6,35	016.0030.160	16.0	9.0	6.2	0.30	0.080	
SO 40003-12.7-10.7	016.0030.269	20.0	12.5	10.5	0.50	0.200	
SO 40003-12.7-10.9	016.0030.271	20.0	12.5	10.7	0.50	0.286	
SO 40003-15.88-14.25 D	016.0030.465	26.0	15.5	14.1	0.50	0.916	

Werkstoff: Messing

Matériau: Laiton

Material: Brass

Verstärken:

Dünnwandige und weiche Rohre sowie alle Kunststoffrohre sind vor dem Einführen in die SERTO Verschraubung mit Stützhülsen zu verstärken. Genaue Angaben über das Verstärken sind den einzelnen Verschraubungsreihen zu entnehmen. Zum Entgraten und Kalibrieren der Rohre eignen sich besonders unsere Hilfswerkzeuge.

Renforcement:

Les tubes présentant une paroi mince, les tubes en matière souple ainsi que les tubes en matière plastique doivent être renforcés à l'aide de douilles d'appui avant d'être introduits dans les raccords SERTO. Des indications plus précises concernant le renforcement sont données pour chaque série de raccord. L'ébarbage et le calibrage du tube sont facilités par l'emploi de notre outil spécial.

Reinforcement:

Thin walled and soft tubes and all plastic tubes, are to be reinforced with stiffener sleeves before insert them into the SERTO union. Exact details concerning stiffening are to be found in the sections on the relevant model series. Our tools are especially useful for deburring and calibrating tubing.

d=Rohraussen- \emptyset
d1=Rohrinnen- \emptyset
s=Rohrwandstärke

d= \emptyset extérieur du tube
d1= \emptyset intérieur de tube
s=épaisseur de la paroi du tube

d=tube outside diameter
d1=tube inside diameter
s=tube wall thickness

Stützhülse

für SERTOflex-Rohre

Douille d'appui

pour tubes SERTOflex

Stiffener sleeve

for SERTOflex tubes

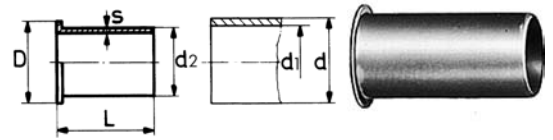

SO 40003 FLEX

Type -d -d1	Mat.-Nr.	L	D	d2	s	kg/100
Für metrische Rohre	Pour tubes métriques			For metric tubes		
SO 40003-6-4 FLEX	440.0035.110	10.0	5.5	3.8	0.20	0.025
SO 40003-8-5,3 FLEX	440.0035.137	12.0	7.5	5.2	0.25	0.045
SO 40003-12-8 FLEX	440.0035.225	20.0	11.5	7.8	0.40	0.190
SO 40003-14-10 FLEX	440.0035.329	24.0	13.5	9.7	0.50	0.320
SO 40003-15-10,5 FLEX	440.0035.412	24.0	14.5	10.3	0.50	0.350
Für Zollrohre	Pour tubes pouces			For inch tubes		
SO 40003-6,35-4,35 FLEX	440.0035.113	10.0	5.5	4.3	0.20	0.025
SO 40003-10-6,35 FLEX	440.0035.177	16.0	9.5	6.0	0.30	0.080

KONVEX S

d=Rohraussen-ø
d1=Rohrinnen-ø
s=Rohrwandstärke

d=ø extérieur du tube
d1=ø intérieur de tube
s=épaisseur de la paroi du tube

d=tube outside diameter
d1=tube inside diameter
s=tube wall thickness

Dichtung für Innengewinde

Joint pour filetage femelle

Washer for female threads

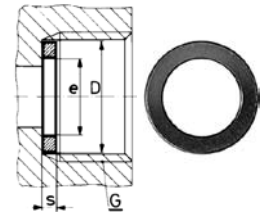

SO 40005

Type -d-G	Mat.-Nr.	D	s	e	kg/100
G=Rohrgewinde (zylindrisch)	G=Filetage-gaz BSP (cylindrique)	G=BSP thread (straight)			
SO 40005-4-1/8	016.0050.060	8.5	2.00	4.0	0.070
SO 40005-5-1/8	016.0050.082	8.5	2.00	4.0	0.070
SO 40005-6-1/4	016.0050.110	11.2	2.00	5.2	0.130
SO 40005-8-1/4	016.0050.170	11.2	2.00	6.8	0.090
SO 40005-8,2-1/4	016.0050.173	11.2	2.00	8.2	0.080
SO 40005-10-3/8	016.0050.280	14.8	2.00	9.0	0.170
SO 40005-10,2-3/8	016.0050.283	14.8	2.00	10.2	0.150
SO 40005-12-1/2	016.0050.400	18.5	2.00	10.0	0.330
SO 40005-14-1/2	016.0050.504	18.5	2.00	13.5	0.210
SO 40005-15-1/2	016.0050.534	18.5	2.00	13.5	0.210
SO 40005-15-3/4	016.0050.536	24.0	2.00	14.2	0.490
SO 40005-17-3/4	016.0050.598	24.0	2.00	16.2	0.410
SO 40005-18-7/8	016.0050.650	27.8	2.00	16.2	0.700
SO 40005-22-1	016.0050.770	30.0	2.00	20.0	0.670

4M

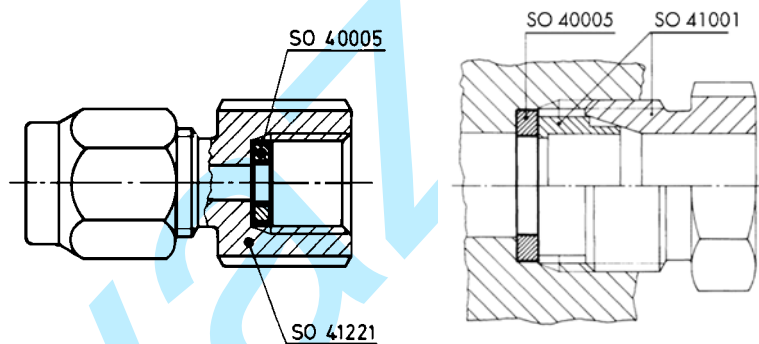
Anwendungsbeispiele:
Exemples d'utilisation:
Sample combinations:

Material: Kupfer, weich

Matériau: Cuivre, doux

Material: Copper, soft

Zu verwenden:

Als Auflage für den Klemmring beim Einschraubstutzen SO 41001. Als stirnseitige Abdichtung in Anschlussgewinde der Verschraubung SO 40030 und SO 41221.

Emploi:

Comme appui d'étanchéité pour la bague de serrage SO 41001. Comme joint frontal pour le filetage femelle des pièces SO 40030 et SO 41221.

Application:

As seat for compression ferrule with nipple connection SO 41001. As butt seal for adaptor thread in unions SO 40030 and SO 41221.

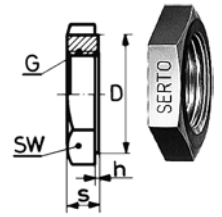
Sechskantmutter METR
Ecrou à six pans METR
Hexagon nut METR

SO 40006 METR

Type -G	Mat.-Nr.	SW	D	s	kg/100
SO 40006-M8X1	016.0063.120	12	11.8	3.50	0.220
SO 40006-M10X1	016.0063.150	14	13.8	4.00	0.270
SO 40006-M12X1	016.0063.190	17	16.8	4.00	0.460
SO 40006-M14X1	016.0063.220	19	18.8	4.00	0.530
SO 40006-M16X1	016.0063.260	19	18.8	4.00	0.380
SO 40006-M20X1	016.0063.340	24	23.8	4.50	0.690
SO 40006-M20X1,5	016.0063.345	27	26.8	6.00	1.640
SO 40006-M24X1,5	016.0063.405	27	26.8	7.00	1.140
SO 40006-M28X1,5	016.0063.445	36	35.8	8.00	3.760

Sechskantmutter für SO 41521, SO 41524 und Ventile

Ecrou à six pans pour SO 41521, SO 41524 et robinets

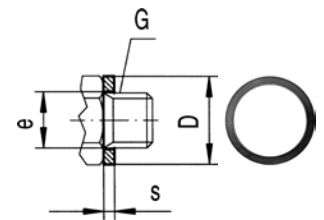
Hexagon nut for SO 41521, SO 41524 and valves

Dichtung für Aussengewinde
Joint pour filetage mâle
Washer for male thread

SO 40507

Type -G	Mat.-Nr.	D	s	e	kg/100
SO 40507-M5	016.0075.080	8.0	1.00	5.2	0.005
SO 40507-M5-2	016.0075.083	8.0	2.00	5.2	0.010
SO 40507-M6	016.0075.100	9.0	1.00	6.2	0.004
SO 40507-M8	016.0075.120	10.0	1.00	8.2	0.003
SO 40507-M10	016.0075.150	12.0	1.00	10.2	0.006

Material: Kunststoff POM

Matériau: Plastique POM

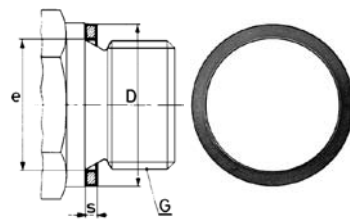
Material: Plastic POM

Dichtung für Aussengewinde
Joint pour filetage mâle
Washer for male threads

SO 40007

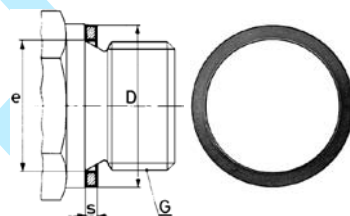
Type -G	Mat.-Nr.	D	s	e	kg/100
G=Rohrgewinde (zylindrisch)	G=Filetage-gaz BSP (cylindrique)	G=BSP thread (straight)			
SO 40007-1/8	016.0070.020	13.4	1.50	10.2	0.050
SO 40007-1/4	016.0070.040	17.9	1.50	14.2	0.110
SO 40007-3/8	016.0070.060	20.9	1.50	17.2	0.130
SO 40007-1/2	016.0070.080	25.9	1.50	21.2	0.220
SO 40007-3/4	016.0070.120	31.0	1.50	26.5	0.230

Dichtung für Aussengewinde METR
Joint pour filetage mâle METR
Washer for male threads METR

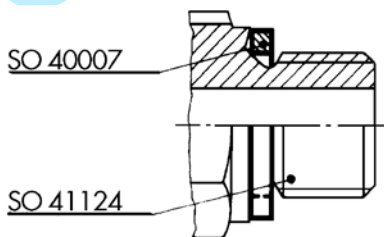
SO 40007 METR

Type -G	Mat.-Nr.	D	s	e	kg/100
SO 40007-M5	016.0073.080	8.0	1.00	5.2	0.023
SO 40007-M6	016.0073.100	8.0	1.00	6.2	0.014
SO 40007-M8	016.0073.173	11.2	2.00	8.2	0.080
SO 40007-M10	016.0073.150	13.4	1.50	10.2	0.050
SO 40007-M12	016.0073.190	15.4	1.50	12.2	0.080
SO 40007-M14	016.0073.220	17.9	1.50	14.2	0.110
SO 40007-M16	016.0073.260	19.9	1.50	16.2	0.120
SO 40007-M18	016.0073.300	22.0	1.50	18.2	0.140
SO 40007-M22	016.0073.370	27.0	1.50	22.2	0.225

4M
Anwendungsbeispiele:
Exemples d'utilisation:
Sample combinations:

Material: Kupfer, weich

Matériau: Cuivre, doux

Material: Copper, soft

Ersatzdichtungen für Schwenkverschraubungen und Mehrfachverteiler.

Joints de rechange pour coudes banjo et coudes banjo multiples.

Replacement washer for single and double banjo.

Zu verwenden:

Emploi:

Application:

Als Abdichtung der Verschraubung mit zylindrischem Einschraubgewinde.

Rendre étanche un filetage cylindrique mâle

As seal for union with straight male adaptor thread.

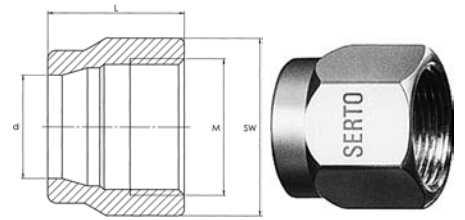
Anschlussmutter
Ecrou
Union nut

SO 40020

Type-d	Mat.-Nr.	bar	M	SW	L	kg/100
Für metrische Rohre	Pour tubes métriques		For metric tubes			
SO 40020-2	016.0200.020	125	6 x 0.75	8	8.5	0.245
SO 40020-3	016.0200.030	125	6 x 0.75	8	10.0	0.270
SO 40020-4	016.0200.040	125	8 x 1	10	13.0	0.510
SO 40020-5	016.0200.050	125	8 x 1	10	13.5	0.500
SO 40020-6	016.0200.060	250	10 x 1	12	14.5	0.720
SO 40020-8	016.0200.080	150	12 x 1	14	16.0	0.950
SO 40020-10	016.0200.100	125	14 x 1	17	18.5	1.640
SO 40020-12	016.0200.120	100	16 x 1	19	19.5	2.010
SO 40020-14	016.0200.140	40	20 x 1.5	24	21.0	4.050
SO 40020-15	016.0200.150	40	20 x 1.5	24	21.0	3.730
SO 40020-16	016.0200.160	40	24 x 1.5	27	24.0	4.790
SO 40020-17	016.0200.170	40	24 x 1.5	27	24.0	4.680
SO 40020-18	016.0200.180	40	24 x 1.5	27	24.0	4.350
SO 40020-22	016.0200.220	25	28 x 1.5	32	27.5	7.150
SO 40020-28	016.0200.280	16	36 x 2	41	31.5	14.300
SO 40020-35	016.0200.350	16	42 x 2	50	36.0	26.200
Für Zollrohre	Pour tubes pouces		For inch tubes			
SO 40020-3,2	016.0200.032	125	6 x 0.75	8	10.0	0.270
SO 40020-6,35	016.0200.063	100	10 x 1	12	14.5	0.710
SO 40020-7,94	016.0200.079	150	12 x 1	14	16.0	0.950
SO 40020-9,52	016.0200.095	64	14 x 1	17	18.5	1.730
SO 40020-15,88	016.0200.158	40	24 x 1.5	27	24.0	4.790
SO 40020-22,22	016.0200.222	25	28 x 1.5	32	27.0	7.020

Armaturenanschluss

Ecrou de raccordement

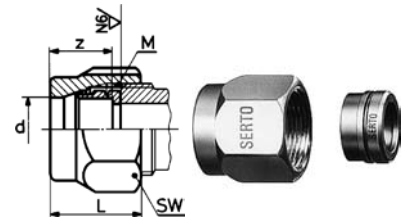
Nut connection



SO 40021

Type -d	Mat.-Nr.	bar	M	SW	L	z	kg/100	
Für metrische Rohre	Pour tubes métriques		For metric tubes					
SO 40021-2	016.0210.020	125	6 x 0.75	8	8.5	4.0	0.260	
SO 40021-3	016.0210.030	125	6 x 0.75	8	10.0	5.0	0.300	
SO 40021-4	016.0210.040	125	8 x 1	10	13.0	6.0	0.570	
SO 40021-5	016.0210.050	125	8 x 1	10	13.5	6.5	0.560	
SO 40021-6	016.0210.060	250	10 x 1	12	14.5	7.5	0.840	
SO 40021-8	016.0210.080	150	12 x 1	14	16.0	8.0	1.120	
SO 40021-10	016.0210.100	125	14 x 1	17	18.5	10.0	1.890	
SO 40021-12	016.0210.120	100	16 x 1	19	19.5	11.0	2.340	
SO 40021-14	016.0210.140	40	20 x 1.5	24	21.0	12.5	4.560	
SO 40021-15	016.0210.150	40	20 x 1.5	24	21.0	12.5	4.240	
SO 40021-16	016.0210.160	40	24 x 1.5	27	24.0	14.0	5.300	
SO 40021-17	016.0210.170	40	24 x 1.5	27	23.0	14.0	5.530	
SO 40021-18	016.0210.180	40	24 x 1.5	27	23.0	14.0	5.260	
SO 40021-22	016.0210.220	25	28 x 1.5	32	27.5	17.5	8.420	
SO 40021-28	016.0210.280	16	36 x 2	41	31.5	19.5	16.700	
SO 40021-35	016.0210.350	16	42 x 2	50	36.0	22.0	29.200	
Für Zollrohre	Pour tubes pouces		For inch tubes					
SO 40021-3.2	016.0210.032	125	6 x 0.75	8	10.0	5.0	0.300	
SO 40021-6,35	016.0210.063	100	10 x 1	12	14.5	7.5	0.830	
SO 40021-7,94	016.0210.079	100	12 x 1	14	16.0	8.0	1.120	
SO 40021-9,52	016.0210.095	64	14 x 1	17	18.5	10.0	1.950	
SO 40021-15.88	016.0210.158	40	24 x 1.5	27	24.0	14.0	5.300	
SO 40021-22.22	016.0210.222	25	28 x 1.5	32	27.0	17.5	8.300	

4M

Manometeranschluss

Ecrou de manomètre

Pressure gauge connection

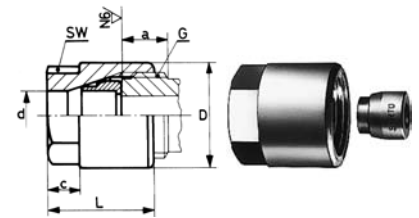

SO 00021 MAN

Type -d-G	Mat.-Nr.	bar	SW	L	a	c	D	kg/100
G=Rohrgewinde (zylindrisch)								

Anwendungsbeispiele:

Exemples d'utilisation:

Sample combinations:

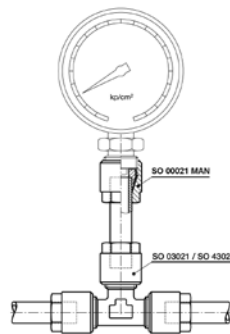

Gewindezapfen für SERTO-Anschlüsse siehe Anhang.

Embout fileté por écrous de raccordement SERTO voir annexe.

Threaded stem for SERTO connections please see appendix.

Armaturenanschluss reduziert

Ecrou de raccordement réduit

Reduction tube connection

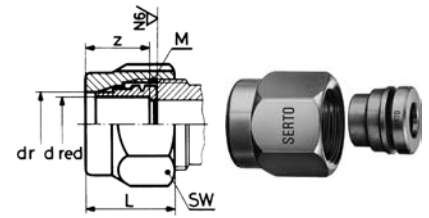

SO 40021 RED

Type -dr -d red	Mat.-Nr.	bar	M	SW	L	dr	z	kg/100
Für metrische Rohre	Pour tubes métriques			For metric tubes				
SO 40021-5-3 RED	016.0214.060	125	8 x 1	10	13.5	5.00	6.5	0.620
SO 40021-6-4 RED	016.0214.110	100	10 x 1	12	14.5	6.00	7.5	0.950
SO 40021-6-5 RED	016.0214.117	100	10 x 1	12	14.5	6.00	7.5	0.900
SO 40021-8-6 RED	016.0214.140	250	12 x 1	14	16.0	8.00	8.0	1.280
SO 40021-10-8 RED	016.0214.190	150	14 x 1	17	18.5	10.00	10.0	2.090
SO 40021-12-10 RED	016.0214.240	100	16 x 1	19	19.5	12.00	11.0	2.620
SO 40021-14-12 RED	016.0214.340	40	20 x 1.5	24	21.0	14.00	12.5	4.940
SO 40021-15-12 RED	016.0214.420	40	20 x 1.5	24	21.0	15.00	12.5	4.780
SO 40021-15-13 RED	016.0214.430	40	20 x 1.5	24	21.0	15.00	12.5	4.670
SO 40021-17-14 RED	016.0214.530	40	24 x 1.5	27	23.0	17.00	14.0	6.240
SO 40021-18-15 RED	016.0214.610	40	24 x 1.5	27	23.0	18.00	14.0	6.010
SO 40021-18-16 RED	016.0214.620	40	24 x 1.5	27	23.0	18.00	14.0	5.780
SO 40021-22-17 RED	016.0214.750	25	28 x 1.5	32	27.5	22.00	17.5	10.180
SO 40021-22-18 RED	016.0214.755	25	28 x 1.5	32	27.5	22.00	17.5	10.000
SO 40021-22-19 RED	016.0214.760	25	28 x 1.5	32	27.5	22.00	17.5	9.800

Für Zollrohre	Pour tubes pouces			For inch tubes				
SO 40021-4-3,2 RED	016.0214.042	125	8 x 1	10	13.0	4.00	6.0	0.600
SO 40021-10-7,94 RED	016.0214.187	64	14 x 1	17	18.5	10.00	10.0	2.090
SO 40021-15-12,7 RED	016.0214.427	40	20 x 1.5	24	21.0	15.00	12.5	4.670
SO 40021-18-15,88 RED	016.0214.618	40	24 x 1.5	27	23.0	18.00	14.0	5.780
SO 40021-22-19,05 RED	016.0214.762	25	28 x 1.5	32	27.5	22.00	17.5	9.800

4M

Anwendungsbeispiele:

Mit diesem Armaturenanschluss SO 40021 RED können einstufige Reduktionen vorgenommen werden. Gewindezapfen für SERTO-Anschlüsse siehe Anhang.

Exemples d'utilisation:

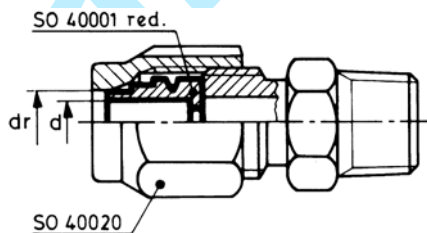

Ces écrous de raccordement SO 40021 RED permettent d'effectuer des réductions d'une dimension. Embout fileté pour écrous de raccordement SERTO voir annexe.

Sample combinations:

This reduction tube connection SO 40021 RED permits single stage reductions to be made. Threaded stem for SERTO connections please see appendix.

Übergangsmuffe Adapteur femelle Female adaptor

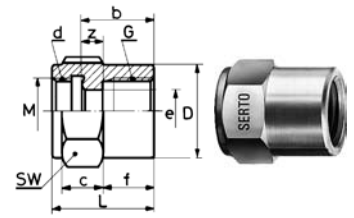

SO 40030

Type -d-G	Mat.-Nr.	bar	M	SW	D	b	c	f	L	z	e	kg/100
G=Rohrgewinde (zylindrisch)	G=Filetage-gaz BSP (cylindrique)		G=BSP thread (straight)									
SO 40030-6-1/8	016.0301.100	250	10 x 1	14	13.8	14.0	8.0	10.0	20.0	4.0	5.0	1.670
SO 40030-6-1/4	016.0301.110	250	10 x 1	17	16.8	15.0	8.0	11.0	21.0	4.0	5.0	2.530
SO 40030-6-3/8	016.0301.120	250	10 x 1	22	21.8	16.0	10.0	10.0	22.0	4.0	5.0	4.800
SO 40030-8-1/8	016.0301.160	150	12 x 1	17	16.8	14.0	9.0	10.0	21.0	4.0	6.5	2.790
SO 40030-8-1/4	016.0301.170	150	12 x 1	17	16.8	16.0	9.0	12.0	23.0	5.0	6.5	2.540
SO 40030-8-3/8	016.0301.180	150	12 x 1	22	21.8	16.0	10.0	11.0	23.0	4.0	6.5	4.780
SO 40030-10-1/4	016.0301.270	125	14 x 1	17	16.8	15.0	8.0	12.0	22.0	4.0	8.5	2.090
SO 40030-10-3/8	016.0301.280	125	14 x 1	22	21.8	17.0	10.0	11.0	23.0	5.0	8.5	4.760
SO 40030-12-1/4	016.0301.380	100	16 x 1	19	18.8	15.0	9.0	11.0	22.0	4.0	10.0	2.780
SO 40030-12-3/8	016.0301.390	100	16 x 1	22	21.8	16.0	10.0	11.0	23.0	4.0	10.0	4.090
SO 40030-12-1/2	016.0301.400	100	16 x 1	27	26.8	18.0	11.0	12.0	25.0	4.0	10.0	7.270
SO 40030-15-3/8	016.0301.532	40	20 x 1.5	24	23.8	17.0	11.0	12.0	25.0	5.0	13.0	5.100
SO 40030-15-1/2	016.0301.534	40	20 x 1.5	27	26.8	19.0	13.0	12.0	27.0	5.0	13.0	7.130
SO 40030-15-3/4	016.0301.536	40	20 x 1.5	32	31.8	22.0	13.0	15.0	30.0	5.0	13.0	10.980
SO 40030-18-1/2	016.0301.646	40	24 x 1.5	30	29.8	20.0	14.0	12.0	28.0	6.0	15.0	9.410
SO 40030-18-3/4	016.0301.648	40	24 x 1.5	32	31.8	23.0	13.0	16.0	31.0	6.0	15.0	10.350
SO 40030-22-3/4	016.0301.768	25	28 x 1.5	36	35.8	23.0	13.0	16.0	31.0	6.0	19.0	14.320
SO 40030-28-1	016.0301.850	16	36 x 2	41	40.8	27.0	16.0	21.0	37.0	7.0	25.0	16.700
SO 40030-35-1 1/4	016.0301.944	16	42 x 2	50	49.8	29.0	20.0	21.0	41.0	7.0	31.0	27.400

Anwendungsbeispiele:

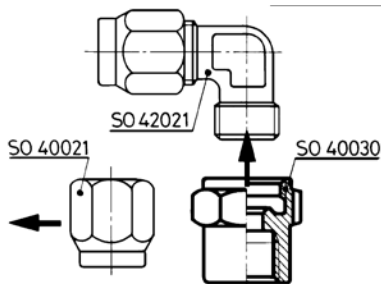

Exemples d'utilisation:

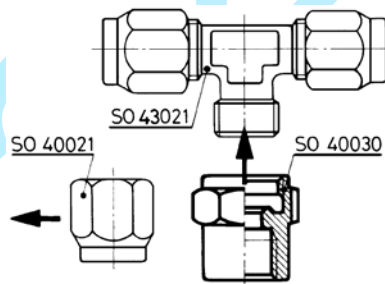

Sample combinations:

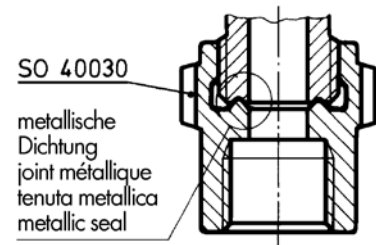

Die Übergangsmuffe SO 40030 kann an jedes SERTO-Formteil mit dem passenden zylindrischen Gewinde M aufgeschraubt werden.

Dichtungsprinzip:

Bei der Montage drückt sich die Dichtkante des Übergangsstückes in das SERTO-Formteil ein, dadurch entsteht eine einwandfrei metallische Dichtung.

Wir empfehlen, dass Gewinde mit einem geeigneten Flüssigklebstoff gegen unbeabsichtigtes Lösen zu sichern.

L'adaptateur femelle SO 40030 peut être monté sur toutes les pièces de forme SERTO avec le filetage cylindrique M correspondant.

Principe d'étanchéité:

Lors du serrage, le bourrelet s'enfonce dans la pièce de forme SERTO et donne un joint métallique parfait.

Nous recommandons de freiner le filetage avec une résine appropriée contre un desserrage ntempestif.

The female adaptor SO 40030 can be screwed onto every SERTO union body with the appropriate straight thread M.

Sealing principle:

On being installed, the lip of the adaptor presses into the SERTO union body, forming a sound metallic seal.

We recommend to secure the thread with a suitable cement against unintended loosening.

Übergangsnippel

Pièce intermédiaire mâle

Male adapter

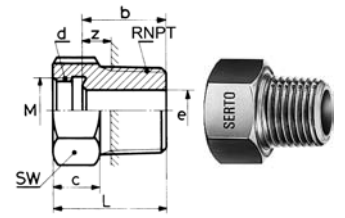

SO 40040

Type - d - R	Mat.-Nr.	bar	M	SW	L	b	c	z	e	kg/100
R=Rohrgewinde (kegelig)	R=Filetage-gaz BSP (conique)	R=BSP thread (tapered)								
SO 40040-6-1/8	016.0401.100	250	10 x 1	12	17.0	11.0	9.0	4.5	5.0	0.800
SO 40040-6-1/4	016.0401.110	250	10 x 1	14	21.0	15.0	9.0	5.3	5.0	1.850
SO 40040-6-3/8	016.0401.120	250	10 x 1	17	20.0	14.0	8.0	4.0	5.0	3.030
SO 40040-6-1/2	016.0401.125	250	10 x 1	22	23.0	17.0	7.0	9.0	4.5	5.700
SO 40040-8-1/8	016.0401.160	150	12 x 1	14	18.0	11.0	10.0	4.5	5.0	0.990
SO 40040-8-1/4	016.0401.170	150	12 x 1	14	22.0	15.0	10.0	5.3	6.5	1.520
SO 40040-8-3/8	016.0401.180	150	12 x 1	17	22.0	15.0	10.0	5.0	6.5	2.970
SO 40040-10-1/4	016.0401.270	125	14 x 1	17	22.0	15.0	10.0	5.3	8.5	1.710
SO 40040-10-3/8	016.0401.280	125	14 x 1	17	22.0	15.0	10.0	4.9	8.5	2.440
SO 40040-10-1/2	016.0401.285	125	14 x 1	22	23.0	16.0	7.0	2.8	8.5	5.030
SO 40040-12-1/4	016.0401.380	100	16 x 1	19	23.0	16.0	11.0	6.3	8.5	2.110
SO 40040-12-3/8	016.0401.390	100	16 x 1	19	23.0	16.0	11.0	5.9	10.0	2.870
SO 40040-12-1/2	016.0401.400	100	16 x 1	22	24.0	17.0	10.0	3.8	10.0	4.840
SO 40040-15-3/8	016.0401.532	40	20 x 1.5	24	24.0	16.0	12.0	5.9	10.0	3.760
SO 40040-15-1/2	016.0401.534	40	20 x 1.5	24	26.0	18.0	12.0	4.8	13.0	4.430
SO 40040-15-3/4	016.0401.536	40	20 x 1.5	27	27.0	19.0	11.0	4.5	13.0	8.250
SO 40040-18-1/2	016.0401.646	40	24 x 1.5	30	27.0	19.0	13.0	5.8	15.0	6.010
SO 40040-18-3/4	016.0401.648	40	24 x 1.5	30	29.0	21.0	13.0	6.5	15.0	8.930
SO 40040-22-1/2	016.0401.764	25	28 x 1.5	36	29.0	21.0	13.0	8.0	15.0	8.910
SO 40040-22-3/4	016.0401.768	25	28 x 1.5	36	29.0	21.0	13.0	6.5	19.0	9.480
SO 40040-28-1	016.0401.850	16	36 x 2	41	38.0	28.0	18.0	11.2	25.0	14.900
SO 40040-35-1 1/4	016.0401.944	16	42 x 2	50	42.0	30.0	20.0	11.0	31.0	26.600

4M

d=Rohraussen- \emptyset
e= kleinste Bohrung
L= Mass in montiertem Zustand

d= \emptyset extérieur du tube
e= \emptyset -min. de passage
L=après montage

d=tube outside diameter
e=minimum bore
L=installed length

Übergangsnippel NPT

Pièce intermédiaire mâle NPT

Male adapter NPT

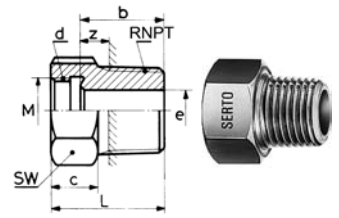

SO 40040 NPT

Type -d -RNPT	Mat.-Nr.	bar	M	SW	L	b	c	z	e	kg/100
RNPT=NPT Gewinde										

Anwendungsbeispiele:

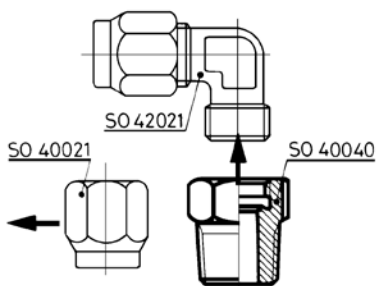

Dichtungsprinzip:
Bei der Montage drückt sich die Dichtkante des Übergangsstückes in das SERTO-Formteil ein. Dadurch entsteht eine einwandfreie metallische Dichtung. Wir empfehlen, das Gewinde mit einem geeigneten Flüssigklebstoff gegen unbeabsichtigtes Lösen zu sichern.

Exemples d'utilisation:

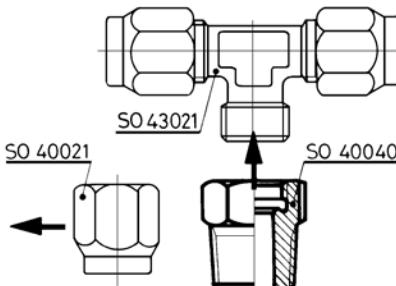

Principe d'étanchéité:
Lors du serrage, l'arête d'étanchéité s'enfonce dans la pièce de forme SERTO et donne un joint métallique parfait. Nous recommandons de freiner le filetage avec une résine appropriée contre un desserrage intempéstif.

Sample combinations:

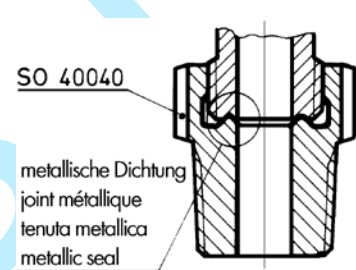

Sealing principle:
On being installed, the lip of the adaptor presses into the SERTO union body, forming a sound metallic seal. We recommend to secure the thread with a suitable cement against unintended loosening.

d=Rohrassen-ø
e= kleinste Bohrung
L= Mass in montiertem Zustand

d=ø extérieur du tube
e= ø-min. de passage
L=après montage

d=tube outside diameter
e=minimum bore
L=installed length

Schlauchtülle

Douille cannelée

Hose nozzle

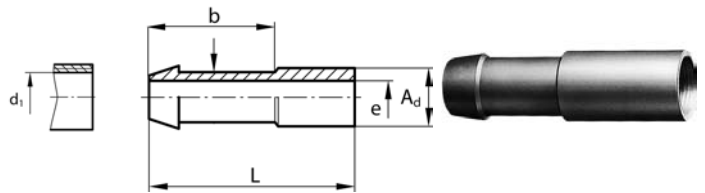

SO 40503

Type -Ad -d1	Mat.-Nr.	L	b	e	kg/100
SO 40503-A4-2,5	016.0500.035	17,0	8,0	2,0	0,090
SO 40503-A5-2,5	016.0500.055	17,0	8,0	2,0	0,120
SO 40503-A5-3	016.0500.060	18,0	9,0	2,5	0,140
SO 40503-A6-2,5	016.0500.095	22,0	8,0	2,0	0,210
SO 40503-A6-3	016.0500.100	23,0	9,0	2,5	0,260
SO 40503-A6-4	016.0500.110	25,0	11,0	3,0	0,270
SO 40503-A6-6	016.0500.122	31,0	17,0	4,0	0,480
SO 40503-A6-8	016.0500.121	31,0	17,0	4,0	0,804
SO 40503-A8-4	016.0500.132	25,0	11,0	3,0	0,275
SO 40503-A8-5	016.0500.136	27,0	13,0	4,0	0,324
SO 40503-A8-6	016.0500.140	31,0	17,0	5,0	0,520
SO 40503-A8-8	016.0500.154	31,0	17,0	6,0	0,710
SO 40503-A8-10	016.0500.157	33,0	19,0	6,0	1,392
SO 40503-A10-8	016.0500.190	35,0	17,0	7,0	0,720
SO 40503-A10-10	016.0500.198	37,0	19,0	7,0	1,370
SO 40503-A10-12	016.0500.199	37,0	19,0	7,0	1,918
SO 40503-A10-13	016.0500.200	39,0	21,0	7,0	2,443
SO 40503-A12-10	016.0500.240	37,0	19,0	8,5	1,230
SO 40503-A12-13	016.0500.260	39,0	21,0	9,0	2,889
SO 40503-A15-13	016.0500.430	41,0	21,0	11,0	2,050
SO 40503-A18-16	016.0500.620	47,0	26,0	14,0	3,240
SO 40503-A22-19	016.0500.760	50,0	26,0	16,0	4,590

4M

Anwendungsbeispiele:

Mit dieser Schlauchtülle können Gummischläuche und Rohre aus Teflon, Weich-PVC, Polyamid usw. direkt an SERTO-Verschraubungen angeschlossen werden. Für die Schlauchsicherung verwenden Sie bitte unsere Schlauchklemme SO 40512.

Exemples d'utilisation:

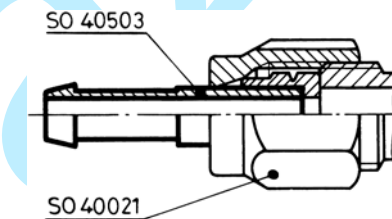

Avec cette douille cannelée, les tuyaux en caoutchouc, les tubes en téflon, en PVC souple, en polyamide et autres peuvent être fixés directement aux raccords SERTO. Afin d'assurer la bonne tenue des tuyaux, utiliser nos colliers de serrage SO 40512.

Sample combinations:

With this hose nozzle, rubber hoses and plastic hoses made of teflon, soft PVC, polyamide can be connected directly to the SERTO unions. Please use our hose clip SO 40512 to securing the hose.

Schlauchtülle vormontiert
Douille cannelée prémontée
Hose nozzle assembly

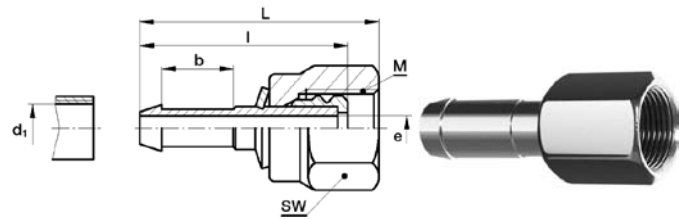
SO 40526

Type -Ad -d1	Mat.-Nr.	M	SW	L	b	l	e	kg/100
SO 40526-A4-2.5	018.0520.035	8 x 1	10	24.0	6.2	18.0	2.0	0.660
SO 40526-A5-2.5	018.0520.055	8 x 1	10	25.0	6.2	19.0	2.0	0.680
SO 40526-A5-3	018.0520.060	8 x 1	10	26.0	6.8	20.0	2.5	0.700
SO 40526-A6-2.5	018.0520.095	10 x 1	12	25.0	6.2	19.0	2.0	1.050
SO 40526-A6-3	018.0520.100	10 x 1	12	26.0	6.8	20.0	2.5	1.100
SO 40526-A6-4	018.0520.110	10 x 1	12	28.0	8.0	22.0	3.0	1.110
SO 40526-A6-8	018.0520.121	10 x 1	12	38.0	8.0	32.0	4.0	1.115
SO 40526-A6-6	018.0520.122	10 x 1	12	38.0	8.0	32.0	4.0	1.320
SO 40526-A8-4	018.0520.132	12 x 1	14	30.0	8.0	23.0	3.0	1.395
SO 40526-A8-5	018.0520.136	12 x 1	14	32.0	10.0	25.0	4.0	1.444
SO 40526-A8-6	018.0520.140	12 x 1	14	36.0	12.0	29.0	4.0	1.640
SO 40526-A8-8	018.0520.154	12 x 1	14	41.0	12.0	34.0	6.0	1.830
SO 40526-A8-10	018.0520.157	12 x 1	14	45.0	12.0	38.0	6.0	2.512
SO 40526-A10-8	018.0520.190	14 x 1	17	39.0	12.0	32.0	6.0	2.610
SO 40526-A10-10	018.0520.198	14 x 1	17	45.0	14.0	38.0	7.0	3.260
SO 40526-A10-12	018.0520.199	14 x 1	17	45.0	14.0	38.0	7.0	3.520
SO 40526-A10-13	018.0520.200	14 x 1	17	45.0	14.0	38.0	7.0	3.550
SO 40526-A12-10	018.0520.240	16 x 1	19	42.0	14.0	35.0	7.0	3.570
SO 40526-A15-13	018.0520.430	20 x 1.5	24	45.0	15.0	38.0	11.0	6.290
SO 40526-A18-16	018.0520.620	24 x 1.5	27	53.0	18.0	45.0	13.0	8.500
SO 40526-A22-19	018.0520.760	28 x 1.5	32	56.0	18.0	48.0	16.0	13.010

Mit dieser Schlauchtülle können Gummischläuche und Rohre aus Teflon, Weich-PVC, Polyamid usw. direkt an SERTO-Verschraubungen angeschlossen werden. Für die Schlauchsicherung verwenden Sie bitte unsere Schlauchklemme SO 40512.

Avec cette douille cannelée, les tuyaux en caoutchouc, les tubes en téflon, en PVC souple, en polyamide et autres peuvent être fixés directement aux raccords SERTO. Afin d'assurer la bonne tenue des tuyaux, utiliser nos colliers de serrage SO 40512.

With this hose nozzle, rubber hoses and plastic hoses made of teflon, soft PVC, polyamide can be connected directly to the SERTO unions. Please use our hose clip SO 40512 to securing the hose.

d1=Rohrinnendurchmesser
 Ad=Aussen-ø der Andrehung
 e= kleinste Bohrung
 L= Mass in montiertem Zustand

ø diam. Intérieur du tube
 Ad=ø extérieur de la portée cylindrique
 e= ø-min. de passage
 L=après montage

d1=tube inside diameter
 Ad= outside diameter of cyl. Stub
 e=minimum bore
 L=installed length

Anschlussnippel
Ecrou de raccordement mâle
Nipple connection

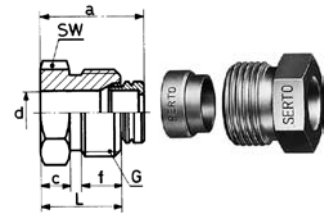

SO 41001

Type -d-G	Mat.-Nr.	bar	SW	L	a	b	c	f	t	kg/100
Für metrische Rohre G=Rohrgewinde (zylindrisch)	Pour tubes métriques G=Filetage-gaz BSP (cylindrique)	For metric tubes G=BSP thread (straight)								
SO 41001-4-1/8	016.1001.060	125	10	12.0	14.5	6.0	4.0	6.0	6.5	0.650
SO 41001-5-1/8	016.1001.082	125	10	12.0	14.5	6.0	4.0	6.0	6.5	0.550
SO 41001-6-1/4	016.1001.110	250	14	16.0	19.0	8.5	6.0	7.5	9.5	1.450
SO 01001-8-1/4	246.1001.170	125	14	16.0	20.0	8.5	6.0	7.5	9.5	1.200
SO 01001-10-3/8	246.1001.280	100	17	17.0	21.0	9.0	6.5	8.0	10.0	2.000
SO 41001-12-1/2	016.1001.400	100	22	20.5	25.0	11.0	8.0	9.5	14.0	4.060
SO 41001-15-1/2	016.1001.534	40	22	19.5	25.0	11.0	8.0	8.5	14.0	3.010

Für Zollrohre	Pour tubes pouces	For inch tubes								
SO 41001-6,35-1/4	016.1001.140	100	14	16.0	18.5	8.5	6.0	7.5	9.5	1.420
SO 01001-9,52-3/8	246.1001.235	100	17	17.0	21.5	8.5	6.5	8.0	9.5	2.094

4M

Anwendungsbeispiele:

Exemples d'utilisation:

Sample combinations:

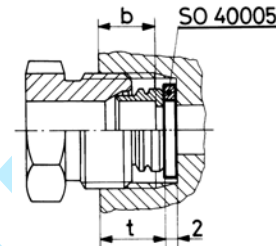

Die entsprechende Kupferdichtung SO 40005 ist immer separat zu bestellen.

Les joints correspondants SO 40005 sont à commander séparément.

The relevant copper washer SO 40005 must always be ordered separately.

Gerade Verschraubung

Union double

Straight union

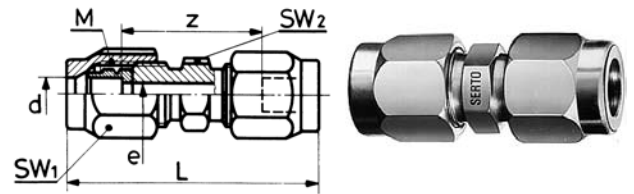

SO 41021

Type -d	Mat.-Nr.	bar	M	SW1	SW2	L	z	e	kg/100
Für metrische Rohre	Pour tubes métriques		For metric tubes						
SO 41021-2	018.1020.020	125	6 x 0.75	8	7	23.5	15.5	2.2	0.810
SO 41021-3	018.1020.030	125	6 x 0.75	8	7	26.0	16.0	2.2	0.890
SO 41021-4	018.1020.040	125	8 x 1	10	10	34.0	22.0	3.5	1.770
SO 41021-5	018.1020.050	125	8 x 1	10	10	35.0	22.0	3.5	1.750
SO 41021-6	018.1020.060	250	10 x 1	12	10	37.5	22.0	4.5	2.520
SO 41021-8	018.1020.080	150	12 x 1	14	12	41.0	25.0	6.5	3.530
SO 41021-10	018.1020.100	125	14 x 1	17	14	46.0	26.0	8.5	5.490
SO 41021-12	018.1020.120	100	16 x 1	19	17	48.5	26.5	10.5	7.030
* SO 41021-13	018.1020.130	40	20 x 1.5	24	22	55.0	31.0	13.0	12.950
SO 41021-14	018.1020.140	40	20 x 1.5	24	22	55.0	32.0	13.0	13.160
SO 41021-15	018.1020.150	40	20 x 1.5	24	22	55.0	32.0	13.0	12.520
SO 41021-16	018.1020.160	40	24 x 1.5	27	24	59.0	33.0	15.0	16.330
SO 41021-17	018.1020.170	40	24 x 1.5	27	24	59.0	33.0	15.0	16.350
SO 41021-18	018.1020.180	40	24 x 1.5	27	24	59.0	33.0	15.0	15.810
* SO 41021-19	018.1020.190	25	28 x 1.5	32	30	69.0	34.0	19.0	27.100
SO 41021-22	018.1020.220	25	28 x 1.5	32	30	69.0	34.0	19.0	24.380
SO 41021-28	018.1020.280	16	36 x 2	41	36	81.0	42.0	25.0	49.320
SO 41021-35	018.1020.350	16	42 x 2	50	46	99.0	48.0	31.0	81.900
Für Zollrohre	Pour tubes pouces		For inch tubes						
SO 41021-6,35	018.1020.063	100	10 x 1	12	10	37.5	22.0	4.5	2.490
SO 41021-9,52	018.1020.095	64	14 x 1	17	14	46.0	26.0	8.5	5.610
* SO 41021-12,7	018.1020.127	40	20 x 1.5	24	22	55.0	31.0	13.0	12.950
SO 41021-15,88	018.1020.158	40	24 x 1.5	27	24	59.0	33.0	15.0	16.330
SO 41021-3.2	018.1020.032	125	6 x 0.75	8	7	26.0	16.0	2.2	0.850

d=Rohrassen-ø
 e=kleinste Bohrung
 L=Mass in montiertem Zustand
 *=mit reduziertem Klemmring

d=ø extérieur du tube
 e=ø-min. de passage
 L=après montage
 *=avec bague de serrage de réduction

d=tube outside diameter
 e=minimum bore
 L=installed length
 *=with reduction compression ferrule

Gerade Verschraubung reduziert
Union double réduite
Straight reduction union

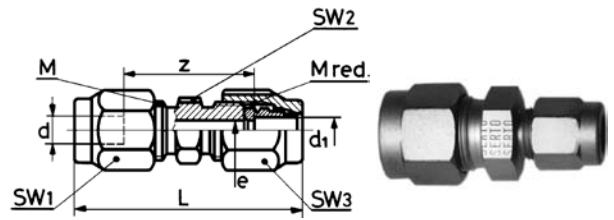

SO 41021 RED

Type - d - d1	Mat.-Nr.	bar	M	M red.	SW1	SW2	SW3	L	z	e	kg/100
Für metrische Rohre	Pour tubes métriques			For metric tubes							
SO 41021-3-2 RED	018.1024.020	125	6 x 0.75		8	7	8	25.0	15.5	2.2	0.850
* SO 41021-5-3 RED	018.1024.060	125	8 x 1		10	10	10	35.0	22.0	3.5	1.810
SO 41021-5-4 RED	018.1024.080	125	8 x 1		10	10	10	34.5	22.0	3.5	0.560
* SO 41021-6-4 RED	018.1024.110	100	10 x 1		12	10	12	37.5	22.5	4.5	2.630
* SO 41021-6-5 RED	018.1024.117	100	10 x 1		12	10	12	37.5	22.5	4.5	2.580
* SO 41021-8-4 RED	018.1024.132	100	12 x 1	10 x 1	14	12	12	39.5	23.5	4.5	3.500
* SO 41021-8-5 RED	018.1024.136	100	12 x 1	10 x 1	14	12	12	39.5	23.5	4.5	3.500
SO 41021-8-6 RED	018.1024.140	250	12 x 1	10 x 1	14	12	12	39.5	24.0	4.5	3.400
* SO 41021-10-8 RED	018.1024.190	150	14 x 1		17	14	17	46.0	26.5	8.5	5.690
* SO 41021-12-8 RED	018.1024.225	40	20 x 1.5	14 x 1	24	22	17	51.0	29.5	8.5	7.210
* SO 41021-12-10 RED	018.1024.240	100	16 x 1		19	17	19	48.5	30.0	10.5	7.310
* SO 41021-14-8 RED	018.1024.308	40	20 x 1.5	14 x 1	24	22	17	51.0	29.5	8.5	6.080
SO 41021-14-10 RED	018.1024.320	40	20 x 1.5	14 x 1	24	22	17	51.0	29.5	8.5	5.850
* SO 41021-14-12 RED	018.1024.340	40	20 x 1.5		24	22	24	55.0	30.0	13.0	13.540
* SO 41021-15-8 RED	018.1024.400	40	20 x 1.5	14 x 1	24	22	17	51.0	29.5	8.5	6.080
SO 41021-15-10 RED	018.1024.410	40	20 x 1.5	14 x 1	24	22	17	51.0	29.5	8.5	5.850
* SO 41021-15-12 RED	018.1024.420	40	20 x 1.5		24	22	24	55.0	30.0	13.0	13.060
* SO 41021-15-13 RED	018.1024.430	40	20 x 1.5		24	22	24	55.0	30.0	13.0	12.950
* SO 41021-16-15 RED	018.1024.510	40	24 x 1.5		27	24	27	59.0	31.0	15.0	16.400
* SO 41021-17-14 RED	018.1024.530	40	24 x 1.5		27	24	27	59.0	31.0	15.0	17.060
* SO 41021-18-15 RED	018.1024.610	40	24 x 1.5		27	24	27	59.0	31.0	15.0	16.560
SO 41021-18-16 RED	018.1024.620	40	24 x 1.5		27	24	27	59.0	31.0	15.0	16.330
* SO 41021-22-17 RED	018.1024.750	25	28 x 1.5		32	30	33	69.0	34.0	19.0	26.140
* SO 41021-22-18 RED	018.1024.755	25	28 x 1.5		32	30	33	69.0	34.0	19.0	25.960
* SO 41021-22-19 RED	018.1024.760	25	28 x 1.5		32	30	33	69.0	34.0	19.0	25.700

Für Zollrohre	Pour tubes pouces			For inch tubes							
SO 41021-6-6,35 RED	018.1024.119	100	10 x 1		12	10	12	37.5	22.5	4.5	2.480
SO 41021-8-6,35 RED	018.1024.143	100	12 x 1	10 x 1	14	12	12	39.5	24.0	4.5	3.400
SO 41021-10-9,52 RED	018.1024.197	64	14 x 1		17	14	17	46.0	26.5	8.5	5.600
SO 41021-14-9,52 RED	018.1024.312	40	20 x 1.5	14 x 1	24	22	17	51.0	29.5	8.5	5.780
SO 41021-15-9,52 RED	018.1024.408	40	20 x 1.5	14 x 1	24	22	17	51.0	29.5	8.5	5.870
* SO 41021-15-12,7 RED	018.1024.427	40	20 x 1.5		24	22	24	55.0	30.0	13.0	12.950

d/d1=Rohraussen-ø
 e=kleinste Bohrung
 L=Mass in montiertem Zustand
 *=mit reduziertem Klemmring

d/d1=ø extérieur du tube
 e=ø-min. de passage
 L=après montage
 *=avec bague de serrage de réduction

d/d1=tube outside diameter
 e=minimum bore
 L=installed length
 *=with reduction compression ferrule

4M

Gerade Einschraubverschraubung
Union mâle
Male adaptor union

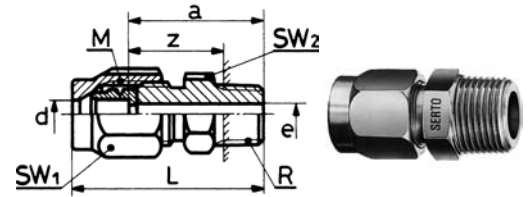

SO 41121

Type -d-R	Mat.-Nr.	bar	M	SW1	SW2	L	a	z	e	kg/100
Für metrische Rohre	Pour tubes métriques		For metric tubes							
SO 41121-2-1/8	018.1101.020	125	6 x 0.75	8	10	22.5	18.5	14.0	2.2	0.880
SO 41121-3-1/8	018.1101.040	125	6 x 0.75	8	10	24.5	19.0	15.0	2.2	0.920
SO 41121-4-1/8	018.1101.060	125	8 x 1	10	10	27.0	21.0	17.0	3.5	1.410
★ SO 41121-4-1/4	018.1101.065	125	10 x 1	12	14	34.5	27.0	21.0	4.5	2.930
★ SO 41121-4-3/8	018.1101.068	125	10 x 1	12	17	34.5	27.0	20.5	4.5	3.500
SO 41121-5-1/8	018.1101.082	125	8 x 1	10	10	27.5	21.0	17.0	3.5	1.390
SO 41121-5-1/4	018.1101.084	125	10 x 1	12	14	34.5	27.0	21.0	4.5	2.880
SO 41121-5-3/8	018.1101.086	125	10 x 1	12	17	34.5	27.0	20.5	4.5	3.450
SO 41121-6-1/8	018.1101.100	250	10 x 1	12	10	28.5	21.0	17.0	4.5	1.690
SO 41121-6-1/4	018.1101.110	250	10 x 1	12	14	34.5	27.0	21.0	4.5	2.820
SO 41121-6-3/8	018.1101.120	250	10 x 1	12	17	34.5	27.0	20.5	4.5	3.390
★ SO 41121-6-1/2	018.1101.125	250	12 x 1	14	22	41.0	33.0	20.0	6.5	6.180
SO 41121-8-1/8	018.1101.160	150	12 x 1	14	12	30.0	22.0	18.0	6.0	2.260
SO 41121-8-1/4	018.1101.170	150	12 x 1	14	14	36.0	28.0	22.0	6.5	3.110
SO 41121-8-3/8	018.1101.180	150	12 x 1	14	17	36.0	28.0	21.5	6.5	3.730
SO 41121-8-1/2	018.1101.185	150	12 x 1	14	22	41.0	33.0	25.0	6.5	6.040
SO 41121-10-1/4	018.1101.270	125	14 x 1	17	14	38.0	28.0	22.0	8.5	3.630
SO 41121-10-3/8	018.1101.280	125	14 x 1	17	17	38.0	28.0	21.5	8.5	4.830
★ SO 41121-10-1/2	018.1101.285	125	14 x 1	17	22	43.0	33.0	25.0	8.5	8.550
SO 41121-12-1/4	018.1101.380	100	16 x 1	19	17	39.0	28.0	22.0	8.5	4.820
SO 41121-12-3/8	018.1101.390	100	16 x 1	19	17	39.0	28.0	21.5	10.5	5.110
SO 41121-12-1/2	018.1101.400	100	16 x 1	19	22	44.0	33.0	25.0	10.5	7.760
★ SO 41121-12-3/4	018.1101.405	100	20 x 1.5	24	27	49.5	37.5	28.0	13.0	11.190
★ SO 41121-13-1/4	018.1101.445	40	20 x 1.5	24	22	43.0	30.5	24.5	8.5	9.200
★ SO 41121-13-3/8	018.1101.450	40	20 x 1.5	24	22	43.0	30.5	24.0	10.5	9.250
★ SO 41121-13-1/2	018.1101.454	40	20 x 1.5	24	22	46.0	35.5	27.5	13.0	9.540
★ SO 41121-13-3/4	018.1101.456	40	20 x 1.5	24	27	49.0	37.0	28.0	13.0	11.080
SO 41121-14-1/4	018.1101.500	40	20 x 1.5	24	22	43.0	30.5	24.5	8.5	9.100
SO 41121-14-3/8	018.1101.502	40	20 x 1.5	24	22	43.0	30.5	24.0	10.5	9.340
SO 41121-14-1/2	018.1101.504	40	20 x 1.5	24	22	48.0	35.5	27.5	13.0	9.430
SO 41121-14-3/4	018.1101.506	40	20 x 1.5	24	27	50.0	37.5	28.0	13.0	10.970
SO 41121-15-1/4	018.1101.528	40	20 x 1.5	24	22	43.0	30.5	24.5	8.5	8.900
SO 41121-15-3/8	018.1101.532	40	20 x 1.5	24	22	43.0	30.5	24.0	10.5	8.820
SO 41121-15-1/2	018.1101.534	40	20 x 1.5	24	22	46.0	35.5	27.5	13.0	9.110
SO 41121-15-3/4	018.1101.536	40	20 x 1.5	24	27	50.0	37.5	28.0	13.0	10.650

Fortsetzung nächste Seite

Suite à la prochaine page

Continued on next page

d=Rohrassen-ø
 e=kleinste Bohrung
 L=Mass in montiertem Zustand
 *=mit reduziertem Klemmring

d=ø extérieur du tube
 e=ø-min. de passage
 L=après montage
 *=avec bague de serrage de réduction

d=tube outside diameter
 e=minimum bore
 L=installed length
 *=with reduction compression ferrule

Gerade Einschraubverschraubung

Union mâle

Male adaptor union

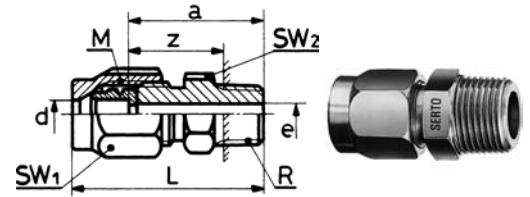

SO 41121

Type -d-R	Mat.-Nr.	bar	M	SW1	SW2	L	a	z	e	kg/100
Für metrische Rohre	Pour tubes métriques			For metric tubes						
SO 41121-16-1/2	018.1101.566	40	24 x 1.5	27	24	50.5	36.5	22.0	15.0	11.280
SO 41121-16-3/4	018.1101.568	40	24 x 1.5	27	27	51.5	37.5	22.5	15.0	12.970
SO 41121-17-1/2	018.1101.596	40	24 x 1.5	27	24	50.5	36.5	22.0	15.0	11.030
SO 41121-17-3/4	018.1101.598	40	24 x 1.5	27	27	51.5	37.5	22.5	15.0	12.720
* SO 41121-17-1	018.1101.602	25	28 x 1.5	32	36	61.0	41.5	26.0	19.0	24.990
SO 41121-18-1/2	018.1101.646	40	24 x 1.5	27	24	50.5	36.5	22.0	15.0	10.760
SO 41121-18-3/4	018.1101.648	40	24 x 1.5	27	27	51.5	37.5	22.5	15.0	12.450
* SO 41121-18-1	018.1101.652	25	28 x 1.5	32	36	61.0	41.5	26.0	19.0	24.840
* SO 41121-19-3/4	018.1101.678	25	28 x 1.5	32	30	55.0	37.5	22.5	19.0	17.800
* SO 41121-19-1	018.1101.686	25	28 x 1.5	32	36	61.0	44.5	26.0	19.0	24.540
SO 41121-22-3/4	018.1101.768	25	28 x 1.5	32	30	55.0	37.5	22.5	19.0	16.440
SO 41121-22-1	018.1101.770	25	28 x 1.5	32	36	61.0	41.5	26.0	19.0	23.330
SO 41121-28-1	018.1101.850	16	36 x 2	41	36	64.5	45.0	29.0	25.0	31.300
SO 41121-35-1 1/4	018.1101.944	16	42 x 2	50	46	75.5	52.0	33.0	31.0	56.300
Für Zollrohre	Pour tubes pouces			For inch tubes						
SO 41121-6,35-1/8	018.1101.135	100	10 x 1	12	10	28.5	21.0	17.0	4.5	1.680
SO 41121-6,35-1/4	018.1101.140	100	10 x 1	12	14	34.5	27.0	21.0	4.5	2.810
SO 41121-6,35-3/8	018.1101.145	100	10 x 1	12	17	34.5	27.0	20.5	4.5	3.350
SO 41121-9,52-1/4	018.1101.230	64	14 x 1	17	14	38.0	28.0	22.0	8.5	3.690
SO 41121-9,52-3/8	018.1101.235	64	14 x 1	17	17	38.0	28.0	21.5	8.5	1.890
* SO 41121-12,7-1/4	018.1101.430	40	20 x 1.5	24	22	43.0	30.5	24.5	8.5	9.200
* SO 41121-12,7-3/8	018.1101.432	40	20 x 1.5	24	22	43.0	30.5	24.0	10.5	9.250
* SO 41121-12,7-1/2	018.1101.434	40	20 x 1.5	24	22	48.0	35.5	27.5	13.0	9.540
* SO 41121-12,7-3/4	018.1101.436	40	20 x 1.5	24	27	49.0	37.0	28.0	13.0	11.080
SO 41121-15,88-1/2	018.1101.541	40	24 x 1.5	27	24	50.5	36.5	22.0	15.0	11.280
* SO 41121-19,05-3/4	018.1101.760	25	28 x 1.5	32	30	55.5	38.0	22.5	19.0	17.800
* SO 41121-22,2-1	018.1101.785	25	28 x 1.5	32	36	62.5	43.0	26.0	19.0	23.300
SO 41121-3,2-1/8	018.1101.045	125	6 x 0.75	8	10	27.5	21.0	17.0	2.2	0.900

4M

d=Rohrassen-ø
 e=kleinste Bohrung
 L=Mass in montiertem Zustand
 *=mit reduziertem Klemmring

d=ø extérieur du tube
 e=ø-min. de passage
 L=après montage
 *=avec bague de serrage de réduction

d=tube outside diameter
 e=minimum bore
 L=installed length
 *=with reduction compression ferrule

Gerade Einschraubverschraubung NPT

Union mâle NPT

Male adaptor union NPT

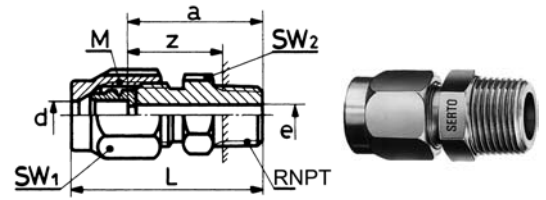

SO 41121 NPT

Type -d -RNPT	Mat.-Nr.	bar	M	SW1	SW2	L	a	z	e	kg/100
Für metrische Rohre RNPT=NPT Gewinde	Pour tubes métriques RNPT=Filetage NPT			For metric tubes RNPT=NPT thread						
* SO 41121-3-1/8 NPT	018.1102.040	125	8 x 1	10	12	30.0	23.5	17.0	3.5	1.710
SO 41121-4-1/8 NPT	018.1102.060	125	8 x 1	10	12	29.5	23.5	17.0	3.5	1.670
* SO 41121-4-1/4 NPT	018.1102.065	125	10 x 1	12	14	36.0	28.5	18.5	4.5	3.230
SO 41121-5-1/8 NPT	018.1102.082	125	8 x 1	10	12	30.0	23.5	17.0	3.5	1.650
* SO 41121-5-1/4 NPT	018.1102.084	125	10 x 1	12	14	36.0	28.5	18.5	4.5	3.180
SO 41121-6-1/8 NPT	018.1102.100	250	10 x 1	12	12	31.0	23.5	17.0	4.5	1.940
SO 41121-6-1/4 NPT	018.1102.110	250	10 x 1	12	14	36.0	28.5	18.5	4.5	3.120
* SO 41121-6-3/8 NPT	018.1102.120	250	12 x 1	14	22	38.0	30.0	20.0	6.5	5.540
* SO 41121-6-1/2 NPT	018.1102.125	250	12 x 1	14	22	44.0	36.0	22.5	6.5	6.200
SO 41121-8-1/4 NPT	018.1102.170	150	12 x 1	14	14	37.5	29.5	19.5	6.5	3.350
* SO 41121-8-3/8 NPT	018.1102.180	150	12 x 1	14	17	38.0	30.0	20.0	6.5	5.540
SO 41121-8-1/2 NPT	018.1102.185	150	12 x 1	14	22	44.0	36.0	22.5	6.5	6.040
SO 41121-10-1/4 NPT	018.1102.270	125	14 x 1	17	14	39.5	29.5	19.5	8.5	3.860
SO 41121-10-3/8 NPT	018.1102.280	125	14 x 1	17	17	40.0	30.0	19.5	8.5	5.340
* SO 41121-10-1/2 NPT	018.1102.285	125	16 x 1	19	17	41.0	30.0	19.5	10.5	10.350
SO 41121-12-1/4 NPT	018.1102.380	100	16 x 1	19	17	41.0	30.0	20.5	8.5	4.980
SO 41121-12-3/8 NPT	018.1102.390	100	16 x 1	19	17	41.0	30.0	19.5	10.5	5.390
SO 41121-12-1/2 NPT	018.1102.400	100	16 x 1	19	22	41.0	30.0	19.5	10.5	10.350
* SO 41121-13-1/2 NPT	018.1102.454	40	20 x 1.5	24	22	47.0	37.5	25.0	13.0	10.240
SO 41121-14-1/2 NPT	018.1102.504	40	20 x 1.5	24	22	47.0	37.5	25.0	13.0	10.130
SO 41121-15-1/2 NPT	018.1102.534	40	20 x 1.5	24	22	47.0	37.5	25.0	13.0	9.810
Für Zollrohre	Pour tubes pouces			For inch tubes						
SO 41121-6,35-1/8 NPT	018.1102.135	100	10 x 1	12	12	31.0	23.5	17.0	4.5	1.930
SO 41121-6,35-1/4 NPT	018.1102.140	100	10 x 1	12	14	36.0	28.5	18.5	4.5	3.110
SO 41121-9,52-1/4 NPT	018.1102.230	64	14 x 1	17	14	39.5	29.5	19.5	8.5	3.920
SO 41121-9,52-3/8 NPT	018.1102.235	64	14 x 1	17	17	40.0	30.0	19.5	8.5	5.340
* SO 41121-12,7-1/2 NPT	018.1102.434	40	20 x 1.5	24	22	47.0	37.5	25.0	13.0	10.240

d=Rohrassen-ø
e=kleinste Bohrung
L=Mass in montiertem Zustand
*=mit reduziertem Klemmring

d=ø extérieur du tube
e=ø-min. de passage
L=après montage
*=avec bague de serrage de réduction

d=tube outside diameter
e=minimum bore
L=installed length
*=with reduction compression ferrule

Gerade Einschraubverschraubung

mit Dichtkante

Union mâle

avec arête d'étanchéité

Male adaptor union

with edge seal

SO 41124

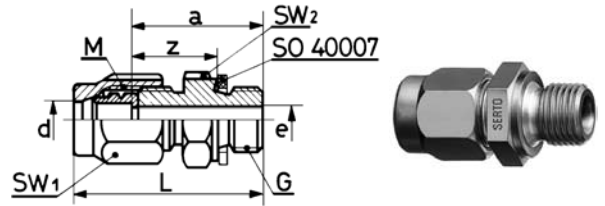

Type - d - G	Mat.-Nr.	bar	M	SW1	SW2	L	a	z	e	kg/100
Für metrische Rohre	Pour tubes métriques		For metric tubes							
G=Rohrgewinde (zylindrisch)	G=Filetage-gaz BSP (cylindrique)		G=BSP thread (straight)							
SO 41124-2-1/8	018.1141.020	125	6 x 0.75	8	14	23.5	19.5	11.5	2.2	1.360
SO 41124-3-1/8	018.1141.040	125	6 x 0.75	8	14	25.0	20.0	12.0	2.2	1.400
SO 41124-4-1/8	018.1141.060	125	8 x 1	10	14	28.5	22.5	14.5	3.5	1.820
* SO 41124-4-1/4	018.1141.065	125	10 x 1	12	19	35.5	28.0	16.0	4.5	3.840
SO 41124-5-1/8	018.1141.082	125	8 x 1	10	14	29.0	22.5	14.5	3.5	1.790
* SO 41124-5-1/4	018.1141.084	125	10 x 1	12	19	35.5	28.0	16.0	4.5	3.790
SO 41124-6-1/8	018.1141.100	250	10 x 1	12	14	30.0	22.5	14.5	4.5	2.070
SO 41124-6-1/4	018.1141.110	250	10 x 1	12	19	35.5	28.0	16.0	4.5	3.730
* SO 41124-6-3/8	018.1141.120	250	12 x 1	14	22	38.5	30.5	18.5	6.5	5.880
SO 41124-6-1/2	018.1141.125	250	12 x 1	14	27	42.0	34.0	20.0	6.5	6.900
SO 41124-8-1/8	018.1141.160	150	12 x 1	14	14	31.5	23.5	15.5	4.5	2.830
SO 41124-8-1/4	018.1141.170	150	12 x 1	14	19	37.0	29.0	17.0	6.5	3.860
SO 41124-8-3/8	018.1141.180	150	12 x 1	14	22	38.5	30.5	18.5	6.5	5.720
SO 41124-8-1/2	018.1141.185	150	12 x 1	14	27	42.0	34.0	20.0	6.5	9.457
SO 41124-10-1/4	018.1141.270	125	14 x 1	17	19	39.0	29.0	17.0	8.5	4.860
SO 41124-10-3/8	018.1141.280	125	14 x 1	17	22	40.5	30.5	18.5	8.5	6.250
* SO 41124-10-1/2	018.1141.285	125	16 x 1	19	27	45.0	34.0	20.0	10.5	7.500
SO 41124-12-1/4	018.1141.380	100	16 x 1	19	19	40.0	29.0	17.0	7.0	5.800
SO 41124-12-3/8	018.1141.390	100	16 x 1	19	22	41.5	30.5	18.5	10.5	6.500
SO 41124-12-1/2	018.1141.400	100	16 x 1	19	27	45.0	34.0	20.0	10.5	7.200
Für Zollrohre	Pour tubes pouces		For inch tubes							
SO 41124-3,2-1/8	018.1141.045	125	6 x 0.75	8	14	25.0	20.0	12.0	2.2	1.300
SO 41124-6,35-1/8	018.1141.135	100	10 x 1	12	14	30.0	22.5	14.5	4.5	2.006
SO 41124-6,35-1/4	018.1141.140	100	10 x 1	12	19	35.5	28.0	16.0	4.5	3.720
SO 41124-9,52-1/4	018.1141.230	64	14 x 1	17	19	39.0	29.0	17.0	8.5	4.920
SO 41124-9,52-3/8	018.1141.235	64	14 x 1	17	22	40.5	30.5	18.5	8.5	6.310

4M

Anwendungsbeispiele:

Exemples d'utilisation:

Sample combinations:

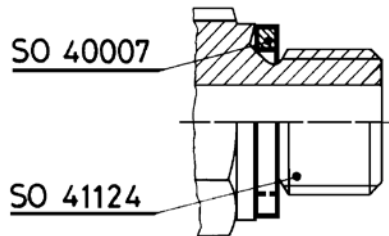

Die entsprechende Dichtung SO 40007 / 40507 ist separat zu bestellen.

Le joint correspondant SO 40007 / 40507 doit être commandé séparément.

The appropriate washer SO 40007 / 40507 is to be ordered separately.

d=Rohrassen-ø
e=kleinste Bohrung
L=Mass in montiertem Zustand
*=mit reduziertem Klemmring

d=ø extérieur du tube
e=ø-min. de passage
L=après montage
*=avec bague de serrage de réduction

d=tube outside diameter
e=minimum bore
L=installed length
*=with reduction compression ferrule

Gerade Einschraubverschraubung METR

mit Dichtkante

Union mâle METR

avec arête d'étanchéité

Male adaptor union METR

with edge seal

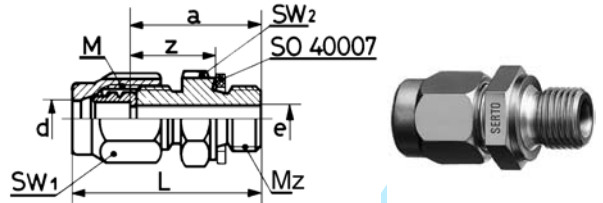

SO 41124 METR

Type -d -Mz	Mat.-Nr.	bar	M	SW1	SW2	L	a	z	e	kg/100
Für metrische Rohre	Pour tubes métriques		For metric tubes							
Mz=metrisches Gewinde (zylindrisch)	Mz=Filetage métrique (cylindrique)		Mz=Metric thread (straight)							
SO 41124-2-M5	018.1143.020	125	6x0.75	8	7	18.0	14.0	10.5	2.2	0.500
SO 41124-3-M5	018.1143.050	125	6x0.75	8	7	19.5	14.5	11.0	2.2	0.540
★ SO 41124-3-M6X0,75	018.1143.055	125	8x1	10	8	25.5	19.0	14.0	2.5	1.110
★ SO 41124-3-M8X1	018.1143.060	125	8x1	10	12	29.0	22.5	15.5	2.8	1.570
SO 41124-4-M5	018.1143.080	125	8x1	10	8	23.0	17.5	14.0	2.2	1.000
SO 41124-4-M6X1	018.1143.086	125	6x1	10	10	24.0	18.0	13.0	2.5	1.050
SO 41124-4-M6X0,75	018.1143.085	125	8x1	10	8	25.0	19.0	14.0	2.5	1.070
SO 41124-4-M8X1	018.1143.090	125	8x1	10	12	28.5	22.5	14.5	2.8	1.530
★ SO 41124-4-M10X1	018.1143.096	125	10x1	12	14	30.0	22.5	14.5	5.0	1.490
SO 41124-5-M5	018.1143.110	125	8x1	10	8	23.5	17.5	14.0	2.2	0.990
SO 41124-5-M6	018.1143.118	125	6x1	10	10	24.5	18.0	13.0	2.5	1.030
SO 41124-5-M6X0,75	018.1143.115	125	8x1	10	8	25.5	19.0	14.0	2.5	1.050
SO 41124-5-M8X1	018.1143.125	125	8x1	10	12	29.0	22.5	14.5	2.8	1.510
★ SO 41124-5-M10X1	018.1143.135	125	10x1	12	14	30.0	22.5	14.5	5.0	1.440
SO 41124-6-M5	018.1143.155	250	10x1	12	10	25.0	17.5	14.0	2.2	1.560
SO 41124-6-M8X1	018.1143.170	250	10x1	12	12	30.0	22.5	14.5	3.5	1.450
SO 41124-6-M10X1	018.1143.180	250	10x1	12	14	30.0	22.5	14.5	5.0	1.380
★ SO 41124-6-M12X1,5	018.1143.195	250	12x1	14	17	37.0	29.0	17.5	5.5	3.760
SO 41124-8-M12X1,5	018.1143.240	150	12x1	14	17	37.0	29.0	17.5	5.5	3.600
★ SO 41124-8-M14X1,5	018.1143.245	150	14x1	17	17	39.0	29.0	17.5	7.5	5.120
SO 41124-10-M12X1,5	018.1143.275	125	14x1	17	17	39.0	29.0	17.5	6.0	4.940
SO 41124-10-M14X1,5	018.1143.280	125	14x1	17	17	39.0	29.0	17.5	7.5	4.920
★ SO 41124-10-M16X1,5	018.1143.285	125	16x1	19	22	42.0	31.0	20.5	9.0	5.780
SO 41124-12-M16X1,5	018.1143.330	100	16x1	19	22	42.0	31.0	20.5	9.0	5.500
★ SO 41124-12-M18X1,5	018.1143.333	100	20x1.5	24	24	46.5	34.0	22.0	11.0	10.820
SO 41124-12-M22X1,5	018.1143.338	100	20x1.5	24	27	48.0	35.5	21.5	13.0	12.350
★ SO 41124-13-M18X1,5	018.1143.365	40	20x1.5	24	24	46.5	34.0	22.0	11.0	10.710
★ SO 41124-13-M22X1,5	018.1143.369	40	20x1.5	24	27	48.0	35.5	21.5	13.0	12.100
SO 41124-14-M18X1,5	018.1143.380	40	20x1.5	24	24	46.5	34.0	22.0	11.0	10.600
SO 41124-14-M22X1,5	018.1143.385	40	20x1.5	24	27	48.0	34.0	21.5	13.0	12.000
SO 41124-15-M18X1,5	018.1143.390	40	20x1.5	24	24	46.5	34.0	22.0	11.0	10.280
SO 41124-15-M22X1,5	018.1143.395	40	20x1.5	24	27	48.0	35.5	21.5	13.0	11.680

Für Zollrohre

Pour tubes pouces

For inch tubes

SO 41124-3,2-M5	018.1143.067	125	6x0.75	8	7	19.5	14.5	11.0	2.2	0.500
SO 41124-6,35-M5	018.1143.205	100	10x1	12	10	25.0	17.5	14.0	2.2	1.550
SO 41124-6,35-M8X1	018.1143.207	125	10x1	12	12	30.0	22.5	14.5	3.5	1.450
SO 41124-6,35-M10X1	018.1143.210	100	10x1	12	14	30.0	22.5	14.5	5.0	2.090
SO 41124-9,52-M12X1,5	018.1143.261	64	14x1	17	17	39.0	29.0	17.5	6.0	5.000
SO 41124-9,52-M14X1,5	018.1143.265	64	14x1	17	17	39.0	29.0	17.5	7.5	4.980
★ SO 41124-12,7-M18X1,5	018.1143.354	40	20x1.5	24	24	46.5	34.0	22.0	11.0	10.710
★ SO 41124-12,7-M22X1,5	018.1143.358	40	20x1.5	24	27	48.0	35.5	21.5	13.0	12.100

d=Rohrassen-ø
e=kleinste Bohrung
L=Mass in montiertem Zustand
*=mit reduziertem Klemmring

d=ø extérieur du tube
e=ø-min. de passage
L=après montage
*=avec bague de serrage de réduction

d=tube outside diameter
e=minimum bore
L=installed length
*=with reduction compression ferrule

Gerade Einschraubverschraubung

mit O-Ringabdichtung (NBR)

Union mâle

avec joint torique (NBR)

Male adaptor union

with O-ring seal (NBR)

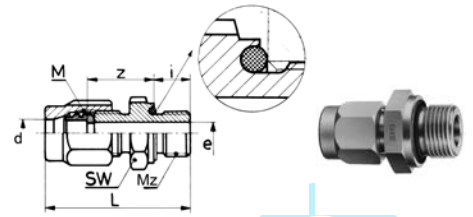

SO 41124 OR

Type -d-G	Mat.-Nr.	bar	M	SW	L	D	i	s	z	e	kg/100
Für metrische Rohre	Pour tubes métriques			For metric tubes							
G=Rohrgewinde (zylindrisch)	G=Filetage-gaz BSP (cylindrique)			G=BSP thread (straight)							
* SO 41124-4-1/8 OR	018.1171.060	100	10 x 1	14	30.0	15.0	8.0	1.00	14.5	4.5	2.300
* SO 41124-4-1/4 OR	018.1171.065	100	10 x 1	19	33.5	19.0	10.0	1.50	16.0	4.5	3.900
* SO 41124-5-1/8 OR	018.1171.082	100	10 x 1	14	30.0	15.0	8.0	1.00	14.5	4.5	2.200
* SO 41124-5-1/4 OR	018.1171.084	100	10 x 1	19	33.5	19.0	10.0	1.50	16.0	4.5	3.900
SO 41124-6-1/8 OR	018.1171.100	250	10 x 1	14	30.0	15.0	8.0	1.00	14.5	4.5	2.000
SO 41124-6-1/4 OR	018.1171.110	250	10 x 1	19	33.5	19.0	10.0	1.50	16.0	4.5	3.900
SO 41124-8-1/4 OR	018.1171.170	150	12 x 1	19	33.5	19.0	10.0	1.50	17.0	6.5	4.000
* SO 41124-8-3/8 OR	018.1171.180	150	14 x 1	22	38.5	23.0	10.0	2.00	18.5	8.5	6.400
SO 41124-10-1/4 OR	018.1171.270	125	14 x 1	19	37.0	19.0	10.0	1.50	17.0	6.5	4.700
SO 41124-10-3/8 OR	018.1171.280	125	14 x 1	22	38.5	23.0	10.0	2.00	18.5	8.5	6.200
* SO 41124-10-1/2 OR	018.1171.285	125	16 x 1	27	42.0	27.0	12.0	2.50	19.0	10.5	7.900
SO 41124-12-3/8 OR	018.1171.390	100	16 x 1	22	39.5	23.0	10.0	2.00	18.5	10.5	6.300
SO 41124-12-1/2 OR	018.1171.400	100	16 x 1	27	42.0	27.0	12.0	2.50	19.0	10.5	7.700
* SO 41124-13-1/2 OR	018.1171.454	40	20 x 1.5	27	46.0	27.0	12.0	2.50	21.5	13.0	13.600
* SO 41124-14-3/8 OR	018.1171.502	40	20 x 1.5	22	44.5	23.0	10.0	2.00	20.0	10.0	11.000
SO 41124-14-1/2 OR	018.1171.504	40	20 x 1.5	27	46.0	27.0	12.0	2.50	21.5	13.0	13.500
SO 41124-15-3/8 OR	018.1171.532	40	20 x 1.5	22	44.5	23.0	10.0	2.00	20.0	10.0	11.000
SO 41124-15-1/2 OR	018.1171.534	40	20 x 1.5	27	46.0	27.0	12.0	2.50	21.5	13.0	13.500
SO 41124-16-1/2 OR	018.1171.566	40	24 x 1.5	27	47.5	27.0	12.0	2.50	21.5	13.0	16.100
SO 41124-17-1/2 OR	018.1171.596	40	24 x 1.5	27	47.5	27.0	12.0	2.50	21.5	13.0	15.500
* SO 41124-17-3/4 OR	018.1171.598	40	28 x 1.5	32	52.0	33.0	12.0	2.50	22.5	19.0	23.800
SO 41124-18-1/2 OR	018.1171.646	40	24 x 1.5	27	47.5	27.0	12.0	2.50	21.5	13.0	15.300
* SO 41124-18-3/4 OR	018.1171.648	25	28 x 1.5	32	52.0	33.0	12.0	2.50	22.5	19.0	23.600
* SO 41124-19-3/4 OR	018.1171.678	25	28 x 1.5	32	52.0	33.0	12.0	2.50	22.5	19.0	23.500
SO 41124-22-3/4 OR	018.1171.768	25	28 x 1.5	32	52.0	33.0	12.0	2.50	22.5	19.0	22.100
Für Zollrohre	Pour tubes pouces			For inch tubes							
SO 41124-6,35-1/8 OR	018.1171.135	100	10 x 1	14	30.0	15.0	8.0	1.00	14.5	4.5	2.100
SO 41124-6,35-1/4 OR	018.1171.140	100	10 x 1	19	33.5	19.0	10.0	1.50	16.0	4.5	3.800
SO 41124-9,52-1/4 OR	018.1171.230	64	14 x 1	19	37.0	19.0	10.0	1.50	17.0	6.5	4.800
SO 41124-9,52-3/8 OR	018.1171.235	64	14 x 1	22	38.5	23.0	10.0	2.00	18.5	8.5	6.100
SO 41124-12,7-1/2 OR	018.1171.434	40	20 x 1.5	27	46.0	27.0	12.0	2.50	21.5	13.0	13.800
* SO 41121-15,88-1/2 OR	018.1171.541	40	24 x 1.5	27	47.5	27.0	12.0	2.50	21.5	13.0	16.100

4M

d=Rohrøussen-ø
e= kleinste Bohrung
L= Mass in montiertem Zustand

d=ø extérieur du tube
e= ø-min. de passage
L=après montage

d=tube outside diameter
e=minimum bore
L=installed length

Gerade Einschraubverschraubung METR

mit O-Ringabdichtung (NBR)

Union mâle METR

avec joint torique (NBR)

Male adaptor union METR

with O-ring seal (NBR)

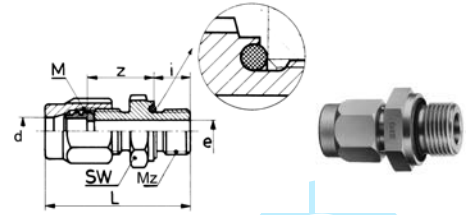

SO 41124 OR METR

Type -d -Mz	Mat.-Nr.	bar	M	SW	L	D	i	s	z	e	kg/100
Für metrische Rohre	Pour tubes métriques					For metric tubes					
Mz=metrisches Gewinde (zylindrisch)	Mz=Filetage métrique (cylindrique)					Mz=Metric thread (straight)					
SO 41124-4-M5 OR	018.1173.080	100	8 x 1	8	23.0	10.0	5.0	0.50	14.0	2.2	1.000
SO 41124-5-M5 OR	018.1173.110	100	8 x 1	8	23.5	10.0	5.0	0.50	14.0	2.2	0.900

Anwendungsbeispiele:

Die Vorteile von conovor® :

- keine Dichtmittelreste in Geräten
- einwandfreie Abdichtung
- keine Beschädigung von Geräten durch konische Gewinde
- schnelle Montage

Temperatur max. 100 °C

Exemples d'utilisation:

Les avantages du conovor®:

- pas de reste de produits d'étanchéité dans les appareils
- étanchéité impeccable
- pas d'endommagement des appareils par des filetages coniques
- montages rapide

Température max. 100 °C

Sample combinations:

The advantages of conovor® :

- no sealing compound residue in instruments
- flawless sealing
- no damage to instruments due to tapered threads
- quick installation

Temperature max. 100 °C

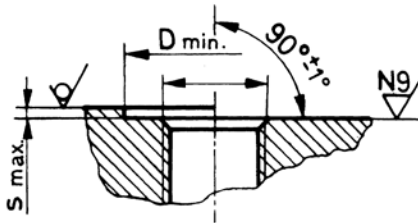

Gerade Aufschraubverschraubung

Union femelle

Female adaptor union

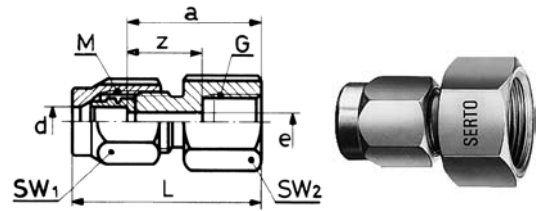
SO 41221

Type -d-G	Mat.-Nr.	bar	M	SW1	SW2	L	a	z	e	kg/100
Für metrische Rohre G=Rohrgewinde (zylindrisch)	Pour tubes métriques G=Filetage-gaz BSP (cylindrique)		For metric tubes G=BSP thread (straight)							
* SO 41221-3-1/8	018.1201.040	125	8 x 1	10	14	28.5	22.0	12.0	3.5	2.060
SO 41221-4-1/8	018.1201.060	125	8 x 1	10	14	28.0	22.0	12.0	3.5	2.000
* SO 41221-4-1/4	018.1201.065	125	10 x 1	12	17	31.5	24.0	13.0	5.0	3.110
SO 41221-5-1/8	018.1201.082	125	8 x 1	10	14	28.5	24.0	12.0	3.5	2.000
* SO 41221-5-1/4	018.1201.084	125	10 x 1	12	17	31.5	24.0	13.0	5.0	3.060
SO 41221-6-1/8	018.1201.100	250	10 x 1	12	14	29.5	22.0	12.0	5.0	2.360
SO 41221-6-1/4	018.1201.110	250	10 x 1	12	17	31.5	24.0	13.0	5.0	3.000
* SO 41221-6-3/8	018.1201.120	250	12 x 1	14	22	33.5	25.5	13.5	6.5	5.100
* SO 41221-6-1/2	018.1201.125	250	12 x 1	14	27	36.5	28.5	14.5	6.5	7.400
SO 41221-8-1/8	018.1201.160	150	12 x 1	14	14	31.0	23.0	13.0	6.5	2.790
SO 41221-8-1/4	018.1201.170	150	12 x 1	14	17	32.5	24.5	13.5	6.5	2.430
SO 41221-8-3/8	018.1201.180	150	12 x 1	14	22	33.5	25.5	13.5	6.5	4.940
SO 41221-8-1/2	018.1201.185	150	12 x 1	14	27	36.5	28.5	14.5	6.5	7.300
SO 41221-10-1/4	018.1201.270	125	14 x 1	17	17	34.5	24.5	13.5	8.5	4.180
SO 41221-10-3/8	018.1201.280	125	14 x 1	17	22	35.5	25.5	13.5	8.5	5.900
* SO 41221-10-1/2	018.1201.285	100	16 x 1	19	27	38.0	28.0	14.0	10.0	9.060
SO 41221-12-1/4	018.1201.380	100	16 x 1	19	17	35.5	24.5	13.5	10.0	4.790
SO 41221-12-3/8	018.1201.390	100	16 x 1	19	22	35.5	25.5	13.5	10.0	6.450
SO 41221-12-1/2	018.1201.400	100	16 x 1	19	27	39.0	28.0	14.0	10.0	8.780
* SO 41221-12-3/4	018.1201.405	40	20 x 1.5	24	32	45.5	33.0	16.0	13.0	14.180
* SO 41221-13-1/2	018.1201.454	40	20 x 1.5	24	27	42.5	30.0	16.0	13.0	11.950
* SO 41221-13-3/4	018.1201.456	40	20 x 1.5	24	32	45.5	33.0	16.0	13.0	14.070
SO 41221-14-1/2	018.1201.504	40	20 x 1.5	24	27	42.5	30.0	16.0	13.0	11.840
SO 41221-14-3/4	018.1201.506	40	20 x 1.5	24	32	45.5	33.0	16.0	13.0	13.960
SO 41221-15-1/2	018.1201.534	40	20 x 1.5	24	27	42.5	30.0	16.0	13.0	11.520
SO 41221-15-3/4	018.1201.536	40	20 x 1.5	24	32	45.5	33.0	16.0	13.0	13.640
SO 41221-16-1/2	018.1201.566	40	24 x 1.5	27	27	44.0	30.0	16.0	15.5	13.270
SO 41221-16-3/4	018.1201.568	40	24 x 1.5	27	32	47.0	33.0	16.0	15.5	15.700
SO 41221-17-1/2	018.1201.596	40	24 x 1.5	27	27	44.0	30.0	16.0	15.5	13.020
SO 41221-17-3/4	018.1201.598	40	24 x 1.5	27	32	47.0	33.0	16.0	15.5	15.450
SO 41221-18-1/2	018.1201.646	40	24 x 1.5	27	27	44.0	30.0	16.0	15.5	12.750
SO 41221-18-3/4	018.1201.648	40	24 x 1.5	27	32	47.0	33.0	16.0	15.5	15.180
* SO 41221-19-3/4	018.1201.678	25	28 x 1.5	32	32	51.5	34.0	17.0	19.0	20.100
SO 41221-22-3/4	018.1201.768	25	28 x 1.5	32	32	51.5	34.0	17.0	19.0	18.710
SO 41221-28-1	018.1201.850	16	36 x 2	41	41	60.5	41.0	21.0	25.0	38.000
SO 41221-35-1 1/4	018.1201.944	16	42 x 2	50	50	72.5	47.0	25.0	31.0	62.500

Fortsetzung nächste Seite

Suite à la prochaine page

Continued on next page

d=Rohrassen-ø
e=kleinste Bohrung
L=Mass in montiertem Zustand
*=mit reduziertem Klemmring

d=ø extérieur du tube
e=ø-min. de passage
L=après montage
*=avec bague de serrage de réduction

d=tube outside diameter
e=minimum bore
L=installed length
*=with reduction compression ferrule

Gerade Aufschraubverschraubung Union femelle Female adaptor union

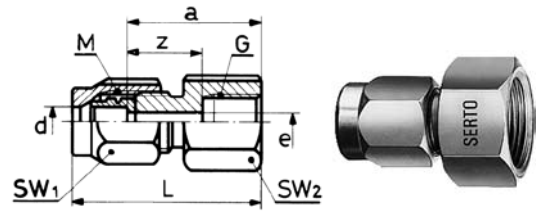
SO 41221

Type -d-G	Mat.-Nr.	bar	M	SW1	SW2	L	a	z	e	kg/100
Für Zollrohre	Pour tubes pouces		For inch tubes							
SO 41221-6,35- $\frac{1}{8}$	018.1201.135	100	10 x 1	12	14	29.5	22.0	12.0	5.0	2.350
SO 41221-6,35- $\frac{1}{4}$	018.1201.140	100	10 x 1	12	17	31.5	24.0	13.0	5.0	2.990
SO 41221-9,52- $\frac{1}{4}$	018.1201.230	64	14 x 1	17	17	34.5	24.5	13.5	8.5	4.240
SO 41221-9,52- $\frac{3}{8}$	018.1201.235	64	14 x 1	17	22	35.5	25.5	13.5	8.0	4.860
* SO 41221-12,7- $\frac{1}{2}$	018.1201.434	40	20 x 1.5	24	27	42.5	30.0	16.0	13.0	11.950
* SO 41221-12,7- $\frac{3}{4}$	018.1201.436	40	20 x 1.5	24	32	45.5	33.0	16.0	13.0	14.070

Gerade Aufschraubverschraubung NPT Union femelle NPT Female adaptor union NPT

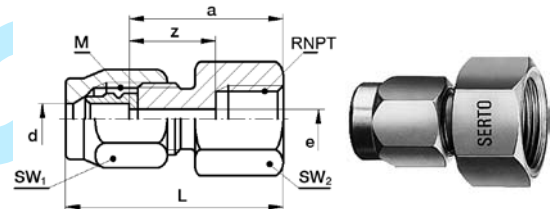
SO 41221 NPT

Type -d-RNPT	Mat.-Nr.	bar	M	SW1	SW2	L	a	z	e	kg/100
Für metrische Rohre	Pour tubes métriques		For metric tubes							
RNPT=NPT Gewinde	RNPT=Filetage NPT		RNPT=NPT thread							
SO 41221-6- $\frac{1}{8}$ NPT	018.1202.100	250	10 x 1	12	14	29.5	22.0	12.0	4.5	2.360
SO 41221-6- $\frac{1}{4}$ NPT	018.1202.110	250	10 x 1	12	17	34.0	26.5	12.5	4.5	2.650
* SO 41221-6- $\frac{3}{8}$ NPT	018.1202.120	250	12 x 1	14	22	36.0	28.0	14.0	6.5	5.100
* SO 41221-8- $\frac{1}{4}$ NPT	018.1202.170	150	14 x 1	17	17	37.0	27.0	13.0	8.5	3.000
SO 41221-8- $\frac{3}{8}$ NPT	018.1202.180	150	12 x 1	14	22	36.0	28.0	14.0	6.5	5.100
SO 41221-10- $\frac{1}{4}$ NPT	018.1202.270	125	14 x 1	17	17	37.0	27.0	13.0	8.5	4.180
* SO 41221-10- $\frac{3}{8}$ NPT	018.1202.280	100	16 x 1	19	22	38.0	28.0	14.0	10.0	7.300
* SO 41221-10- $\frac{1}{2}$ NPT	018.1202.285	100	16 x 1	19	27	42.5	32.5	14.5	10.0	9.000
SO 41221-12- $\frac{3}{8}$ NPT	018.1202.390	100	16 x 1	19	22	38.0	28.0	14.0	10.0	8.900
SO 41221-12- $\frac{1}{2}$ NPT	018.1202.400	100	16 x 1	19	27	42.5	32.5	14.5	10.0	9.000
Für Zollrohre	Pour tubes pouces		For inch tubes							
SO 41221-6.35- $\frac{1}{8}$ NPT	018.1202.135	100	10 x 1	12	14	29.5	22.0	12.0	4.5	2.350
SO 41221-6.35- $\frac{1}{4}$ NPT	018.1202.140	100	10 x 1	12	17	34.0	26.5	12.5	4.5	2.640
SO 41221-9.52- $\frac{1}{4}$ NPT	018.1202.230	64	14 x 1	17	17	37.0	27.0	13.0	8.5	4.240

d=Rohrassen- \varnothing
e=kleinste Bohrung
L=Mass in montiertem Zustand
*=mit reduziertem Klemmring

d= \varnothing extérieur du tube
e= \varnothing -min. de passage
L=après montage
*=avec bague de serrage de réduction

d=tube outside diameter
e=minimum bore
L=installed length
*=with reduction compression ferrule

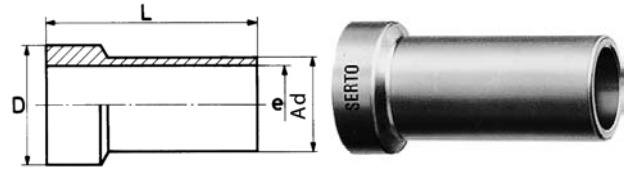
Verbindungsrippel
Pièce folle
Tube stub
SO 41300

Type -Ad	Mat.-Nr.	bar	L	D	e	kg/100
SO 41300-A6	016.1300.060	100	19.0	8.4	4.0	0.350
SO 41300-A8	016.1300.080	100	21.5	10.5	6.0	0.520
SO 41300-A10	016.1300.100	64	25.5	12.7	8.0	0.850
SO 41300-A12	016.1300.120	64	27.5	14.7	9.0	1.400
SO 41300-A14	016.1300.140	40	30.5	17.5	11.0	2.000
SO 41300-A15	016.1300.150	40	31.0	18.0	12.0	2.100
SO 41300-A17	016.1300.170	40	33.0	21.0	14.0	2.900
SO 41300-A18	016.1300.180	40	35.5	22.0	15.0	3.200
SO 41300-A22	016.1300.220	25	39.5	26.0	19.0	4.100
SO 41300-A28	016.1300.280	16	46.5	32.5	23.0	9.800

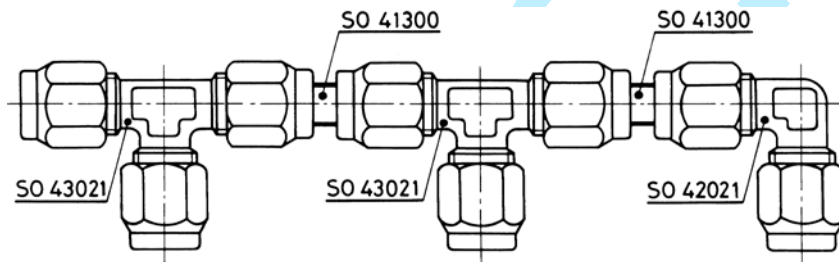
Anwendungsbeispiele:
Exemples d'utilisation:
Sample combinations:

Mit der einstellbaren Kupplung lassen sich alle Formteile mit dem gleichen Anschlussgewinde M verbinden. Weitere einstellbare Verschraubungen siehe SO 41600, SO 42621, SO 42824, SO 43621, SO 43824, SO 43924.

L'union orientable permet l'assemblage de tous les raccords de même filetage mâle M. Autres raccords orientables, voir SO 41600, SO 42621, SO 42824, SO 43621, SO 43824, SO 43924.

The adjustable coupling permits the connection of all fittings with the same connector thread M. See SO 41600, SO 42621, SO 42824, SO 43621, SO 43824, SO 43924 for other adjustable unions.

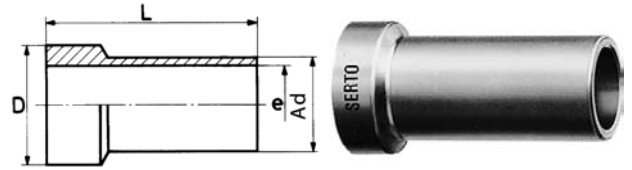
Verbindungsrippel
Pièce folle
Tube stub
SO 41304

Type -Ad	Mat.-Nr.	bar	L	D	e	kg/100
radial demontierbar	démontable radialement				radial dismantling	
SO 41304-A6	016.1310.060	250	29.0	8.4	4.0	0.470
SO 41304-A8	016.1310.080	125	32.0	10.5	6.0	0.700
SO 41304-A10	016.1310.100	125	37.0	12.7	8.0	1.040
SO 41304-A12	016.1310.120	100	39.0	14.7	9.0	1.800

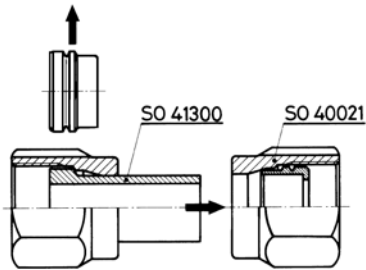
Anwendungsbeispiele:

Die Verbindungsrippel SO 41300/41304 montiert mit Anschlussmutter SO 40020 d und Armaturenanschluss SO 40021 d ergibt eine einstellbare Kupplung.

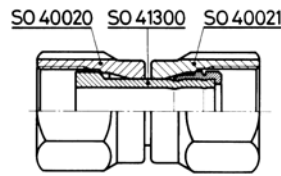
Exemples d'utilisation:

La pièce folle SO 41300/41304 montée avec les écrous SO 40020 d et SO 40021 d donne une union orientable.

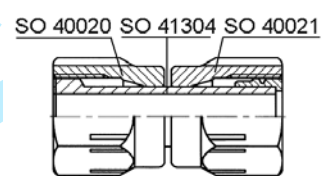
Sample combinations:

The tube stub SO 41300/41304 assembled together with the union nut SO 40020 d and the nut connection SO 40021 d provides an adjustable coupling.

**Einstellbare Kupplung
Accouplement orientable
Adjustable coupling**

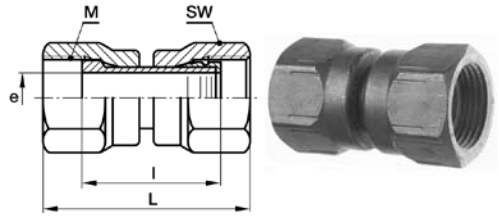

SO 41325

Type -Ad	Mat.-Nr.	bar	M	SW1	l	L	e	kg/100
SO 41325-A6	018.1320.060	250	10 x 1	12	20.0	31.0	4.0	2.050
SO 41325-A8	018.1320.080	150	12 x 1	14	23.0	35.0	6.0	2.750
SO 41325-A10	018.1320.100	125	14 x 1	12	26.0	38.0	8.0	4.650
SO 41325-A12	018.1320.120	100	12 x 1	19	29.0	41.0	9.0	6.150
SO 41325-A14	018.1320.140	40	20 x 1.5	14	32.0	45.0	11.0	11.100
SO 41325-A15	018.1320.150	40	20 x 1.5	14	32.0	45.0	12.0	10.600
SO 41325-A18	018.1320.180	40	24 x 1.5	17	37.0	51.0	15.0	13.700
SO 41325-A22	018.1320.220	25	28 x 1.5	22	41.0	55.0	19.0	20.900
SO 41325-A28	018.1320.280	16	36 x 2	14	49.0	66.0	23.0	43.200

**Einstellbare Kupplung
Accouplement orientable
Adjustable coupling**

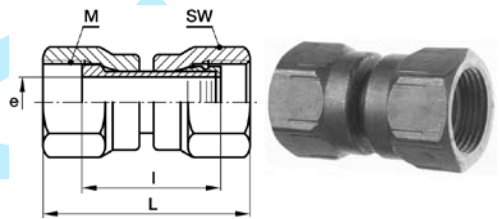

SO 41326

Type -Ad	Mat.-Nr.	bar	M	SW1	l	L	e	kg/100
Für metrische Rohre	Pour tubes métriques					For metric tubes		
SO 41326-A6	018.1330.060	250	10 x 1	17	30.0	41.0	4.0	2.150
SO 41326-A8	018.1330.080	150	12 x 1	22	33.0	45.0	6.0	2.950
SO 41326-A10	018.1330.100	125	14 x 1	22	38.0	50.0	8.0	4.800
SO 41326-A12	018.1330.120	100	16 x 1	17	40.0	52.0	9.0	6.500

Mit der einstellbaren Kupplung lassen sich alle Formteile mit dem gleichen Anschlussgewinde M verbinden. Weitere einstellbare Verschraubungen siehe SO 41600, SO 42621, SO 42824, SO 43621, SO 43824.

L'union orientable permet l'assemblage de tous les raccords de même filetage mâle M. Autres raccords orientables, voir SO 41600, SO 42621, SO 42824, SO 43621, SO 43824, SO 43924.

The adjustable coupling permits the connection of all fittings with the same connector thread M. For other adjustable unions see SO 41600, SO 42621, SO 42824, SO 43621, SO 43824.

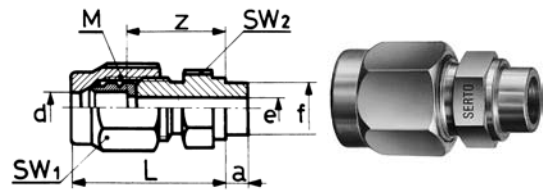
Verschraubung mit Einlötnippel
Union avec embout à braser
Adaptor union with soldering nipple

SO 41421

Type -d -f	Mat.-Nr.	bar	M	SW1	SW2	L	a	f	z	e	kg/100
Für metrische Rohre	Pour tubes métriques		For metric tubes								
* SO 41421-4-6	018.1400.060	125	10 x 1	12	10	21.5	3.0	6.0	14.0	4.0	1.640
* SO 41421-5-6	018.1400.080	125	10 x 1	12	10	21.5	3.0	6.0	14.0	4.0	1.590
SO 41421-6-6	018.1400.100	250	10 x 1	12	10	21.5	3.0	6.0	14.0	4.0	1.530
SO 41421-8-9	018.1400.140	150	12 x 1	14	12	24.0	4.0	9.0	16.0	6.0	2.200
SO 41421-10-11	018.1400.180	125	14 x 1	17	14	27.0	5.0	11.0	17.0	8.0	3.385
SO 41421-12-14	018.1400.200	100	16 x 1	19	17	29.0	6.0	14.0	18.0	10.0	4.530
* SO 41421-13-17	018.1400.240	40	20 x 1.5	24	22	33.5	6.0	17.0	20.5	13.0	8.330
SO 41421-14-17	018.1400.260	40	20 x 1.5	24	22	33.5	6.0	17.0	20.5	13.0	8.220
SO 41421-15-17	018.1400.280	40	20 x 1.5	24	22	33.5	6.0	17.0	20.5	13.0	7.900
SO 41421-16-19	018.1400.300	40	24 x 1.5	27	24	36.5	7.0	19.0	21.5	15.0	10.800
SO 41421-17-19	018.1400.320	40	24 x 1.5	27	24	36.5	7.0	19.0	21.5	15.0	10.550
SO 41421-18-19	018.1400.340	40	24 x 1.5	27	24	36.5	7.0	19.0	21.5	15.0	10.280
* SO 41421-19-23	018.1400.360	25	28 x 1.5	32	30	41.5	7.0	23.0	23.5	19.0	17.080
SO 41421-22-23	018.1400.400	25	28 x 1.5	32	30	41.5	7.0	23.0	23.5	19.0	15.680
Für Zollrohre	Pour tubes pouces		For inch tubes								
SO 41421-6,35-6	018.1400.120	100	10 x 1	12	10	21.5	3.0	6.0	14.0	4.0	1.520
SO 41421-9,52-11	018.1400.160	64	14 x 1	17	14	27.0	5.0	11.0	17.0	8.0	3.440
* SO 41421-12,7-17	018.1400.220	40	20 x 1.5	24	22	33.5	6.0	17.0	20.5	13.0	8.330

d=Rohrassen-ø
 e=kleinste Bohrung
 L=Mass in montiertem Zustand
 *=mit reduziertem Klemmring

d=ø extérieur du tube
 e=ø-min. de passage
 L=après montage
 *=avec bague de serrage de réduction

d=tube outside diameter
 e=minimum bore
 L=installed length
 *=with reduction compression ferrule

Gerade Schottverschraubung

Durchführungslänge max. 5 mm

Union double pour passage de cloison

Pour cloison max. 5 mm

Panel mount union

Max. panel thickness 5 mm

SO 41521

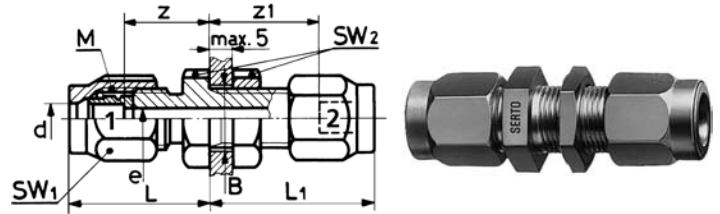

Type-d	Mat.-Nr.	bar	M	SW1	SW2	L	L1	B	z1	z	e	kg/100
Für metrische Rohre	Pour tubes métriques			For metric tubes								
* SO 41521-3	018.1500.030	125	8 x 1	10	12	19.5	24.5	8.5	18.5	13.5	3.5	2.580
SO 41521-4	018.1500.040	125	8 x 1	10	12	19.5	24.5	8.5	18.5	13.5	3.5	2.460
SO 41521-5	018.1500.050	125	8 x 1	10	12	20.0	25.0	8.5	18.5	13.5	3.5	2.440
SO 41521-6	018.1500.060	250	10 x 1	12	14	21.0	26.5	10.5	19.0	13.5	4.5	3.540
SO 41521-8	018.1500.080	150	12 x 1	14	17	23.0	28.0	12.5	20.0	15.0	6.5	5.320
SO 41521-10	018.1500.100	125	14 x 1	17	19	25.5	31.0	14.5	21.0	15.5	8.5	7.710
SO 41521-12	018.1500.120	100	16 x 1	19	22	27.0	32.0	16.5	21.0	16.0	10.5	9.320
* SO 41521-13	018.1500.130	40	20 x 1.5	24	27	34.5	39.5	20.5	24.5	19.5	13.0	16.510
SO 41521-14	018.1500.140	40	20 x 1.5	24	27	34.5	39.5	20.5	24.5	19.5	13.0	16.720
SO 41521-15	018.1500.150	40	20 x 1.5	24	27	34.5	39.5	20.5	24.5	19.5	13.0	16.080
SO 41521-16	018.1500.160	40	24 x 1.5	27	30	36.5	41.5	24.5	24.5	19.5	15.0	19.500
SO 41521-18	018.1500.180	40	24 x 1.5	27	30	36.5	41.5	24.5	24.5	19.5	15.0	18.500
Für Zollrohre	Pour tubes pouces			For inch tubes								
SO 41521-6,35	018.1500.063	100	10 x 1	12	14	21.0	26.5	10.5	19.0	13.5	4.5	3.510
SO 41521-9,52	018.1500.095	64	14 x 1	17	19	25.5	31.0	14.5	21.0	15.5	8.5	7.830
* SO 41521-12,7	018.1500.127	40	20 x 1.5	24	27	34.5	39.5	20.5	24.5	19.5	13.0	16.510

4M

d=Rohraussen-ø
 e=kleinste Bohrung
 L=Mass in montiertem Zustand
 *=mit reduziertem Klemmring

d=ø extérieur du tube
 e=ø-min. de passage
 L=après montage
 *=avec bague de serrage de réduction

d=tube outside diameter
 e=minimum bore
 L=installed length
 *=with reduction compression ferrule

Gerade Schottverschraubung reduziert

Durchführungslänge max. 5 mm

Union double réduite pour passage de cloison

pour cloison max. 5 mm

Panel mount reduction union

max. panel thickness 5 mm

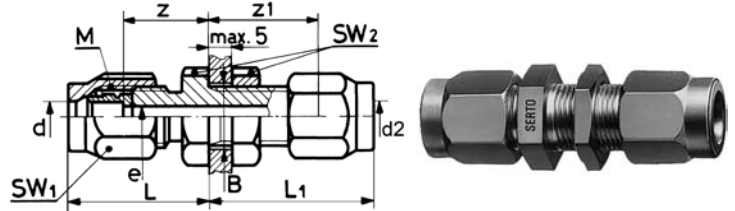

SO 41521 RED

Type -d -d2	Mat.-Nr.	bar	M	SW1	SW2	L	L1	B	z1	z	e	kg/100
Für metrische Rohre	Pour tubes métriques			For metric tubes								
* SO 41521-5-3	018.1504.060	125	8 x 1	10	12	20.0	25.0	8.5	18.5	13.5	3.5	2.500
* SO 41521-6-4	018.1504.110	100	10 x 1	12	14	21.0	26.5	10.5	19.0	13.5	4.5	3.650
* SO 41521-6-5	018.1504.117	100	10 x 1	12	14	21.0	26.5	10.5	19.0	13.5	4.5	3.600
* SO 41521-8-6	018.1504.140	250	12 x 1	14	17	23.0	28.0	12.5	20.0	15.0	6.5	5.480
* SO 41521-10-8	018.1504.190	150	14 x 1	17	19	25.5	31.0	14.5	21.0	15.5	8.5	7.910
* SO 41521-12-10	018.1504.240	100	16 x 1	19	22	27.0	32.0	16.5	21.0	16.0	10.5	9.600
* SO 41521-15-12	018.1504.420	40	20 x 1.5	24	27	34.5	39.5	20.5	24.5	19.5	13.0	16.620
* SO 41521-15-13	018.1504.430	40	20 x 1.5	24	27	34.5	39.5	20.5	24.5	19.5	13.0	16.510
* SO 41521-18-15	018.1504.610	40	24 x 1.5	27	30	36.5	41.5	24.5	24.5	19.5	15.0	18.400
Für Zollrohre	Pour tubes pouces			For inch tubes								
SO 41521-6-6,35	018.1504.119	100	10 x 1	12	14	21.0	26.5	10.5	19.0	13.5	4.5	3.530
SO 41521-10-9,52	018.1504.197	64	14 x 1	17	19	25.5	31.0	14.5	21.0	15.5	8.5	7.780
* SO 41521-15-12,7	018.1504.427	40	20 x 1.5	24	27	34.5	39.5	20.5	24.5	19.5	13.0	16.510

Weitere Reduktionen siehe SO 41821
Sechskanmutter siehe SO 40006

Autres réductions voir SO 41821
Ecroû à six pans voir SO 40006

Alternative reductions see SO 41821
Hexagon nut see SO 40006

d=Rohraussen-ø
e=kleinste Bohrung
L=Mass in montiertem Zustand
*=mit reduziertem Klemmring

d=ø extérieur du tube
e=ø-min. de passage
L=après montage
*=avec bague de serrage de réduction

d=tube outside diameter
e=minimum bore
L=installed length
*=with reduction compression ferrule

Gerade Schottverschraubung

Durchführungslänge max. 16 mm

Union double pour passage de cloison

pour cloison max. 16 mm

Panel mount union

max. panel thickness 16 mm

SO 41524

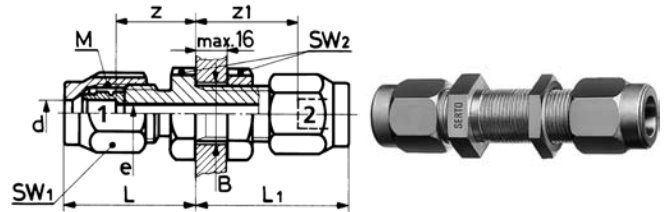

Type -d1 -d2	Mat.-Nr.	bar	M	SW1	SW2	L	L1	B	z1	z	e	kg/100
Für metrische Rohre	Pour tubes métriques			For metric tubes								
* SO 41524-4	018.1540.040	125	10 x 1	12	14	21.0	37.5	10.5	30.0	13.5	4.5	4.130
* SO 41524-5	018.1540.050	125	10 x 1	12	14	21.0	37.5	10.5	30.0	13.5	4.5	4.080
SO 41524-6	018.1540.060	250	10 x 1	12	14	21.0	37.5	10.5	30.0	13.5	4.5	4.020
SO 41524-8	018.1540.080	150	12 x 1	14	17	23.0	39.0	12.5	31.0	15.0	6.5	6.030
SO 41524-10	018.1540.100	125	14 x 1	17	19	25.5	42.0	14.5	32.0	15.5	8.5	8.520
SO 41524-12	018.1540.120	100	16 x 1	19	22	27.0	43.0	16.5	32.0	16.0	10.5	10.220
* SO 41524-13	018.1540.130	40	20 x 1.5	24	27	34.5	50.5	20.5	33.5	19.5	13.0	17.740
SO 41524-14	018.1540.140	40	20 x 1.5	24	27	34.5	50.5	20.5	33.5	19.5	13.0	17.950
SO 41524-15	018.1540.150	40	20 x 1.5	24	27	34.5	50.5	20.5	33.5	19.5	13.0	17.310
SO 41524-16	018.1540.160	40	24 x 1.5	27	30	39.5	50.5	24.5	33.5	19.5	15.0	25.800
* SO 41524-17	018.1540.170	40	24 x 1.5	27	30	39.5	50.5	24.5	33.5	19.5	15.0	25.350
SO 41524-18	018.1540.180	40	24 x 1.5	27	30	39.5	50.5	24.5	33.5	19.5	15.0	24.850
* SO 41524-19	018.1540.190	40	28 x 1.5	32	36	40.5	55.5	28.5	35.5	20.5	19.0	34.200
SO 41524-22	018.1540.220	40	28 x 1.5	32	36	40.5	55.5	28.5	35.5	20.5	19.0	31.500
Für Zollrohre	Pour tubes pouces			For inch tubes								
SO 41524-6,35	018.1540.063	100	10 x 1	12	14	21.0	37.5	10.5	30.0	13.5	4.5	3.990
SO 41524-9,52	018.1540.095	64	14 x 1	17	19	25.5	42.0	14.5	32.0	15.5	8.5	8.640
* SO 41524-12,7	018.1540.127	40	20 x 1.5	24	27	34.5	50.5	20.5	33.5	19.5	13.0	17.740

Sechskantmutter siehe SO 40006

Ecrou à six pans voir SO 40006

Hexagon nut see SO 40006

d=Rohrassen-ø
e=kleinste Bohrung
L=Mass in montiertem Zustand
*=mit reduziertem Klemmring

d=ø extérieur du tube
e=ø-min. de passage
L=après montage
*=avec bague de serrage de réduction

d=tube outside diameter
e=minimum bore
L=installed length
*=with reduction compression ferrule

Gerade Schottverschraubung reduziert

Durchführungslänge max. 16 mm

Union double réduite pour passage de cloison

Pour cloison max. 16 mm

Panel mount reduction union

Max. panel thickness 16 mm

SO 41524 RED

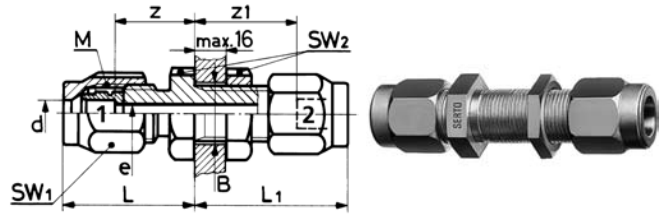

Type -d1 -d2	Mat.-Nr.	bar	M	SW1	SW2	L	L1	B	z	z1	e	kg/100
Für metrische Rohre	Pour tubes métriques			For metric tubes								
* SO 41524-6-4	018.1544.110	100	10x1	12	14	22.5	39.0	10.5	13.5	30.0	4.5	4.130
* SO 41524-6-5	018.1544.117	100	10x1	12	14	22.5	39.0	10.5	13.5	30.0	4.5	4.080
* SO 41524-8-6	018.1544.140	250	12x1	14	17	23.0	41.5	12.5	15.0	32.0	6.5	6.190
* SO 41524-10-8	018.1544.190	150	14x1	17	19	28.0	44.5	14.5	15.5	32.0	8.5	8.720
* SO 41524-12-10	018.1544.240	100	16x1	19	22	30.0	46.0	16.5	16.0	32.0	10.5	10.500
* SO 41524-15-12	018.1544.420	40	20x1.5	24	27	34.5	50.5	20.5	18.0	32.5	13.0	17.850
* SO 41524-15-13	018.1544.430	40	20x1.5	24	27	34.5	50.5	20.5	18.0	33.0	13.0	17.740
Für Zollrohre	Pour tubes pouces			For inch tubes								
SO 41524-6-6,35	018.1544.119	100	10x1	12	14	22.5	37.5	10.5	13.5	30.0	4.5	4.010
SO 41524-10-9,52	018.1544.197	64	14x1	17	19	28.0	42.0	14.5	15.5	32.0	8.5	8.580
* SO 41524-15-12,7	018.1544.427	40	20x1.5	24	27	30.5	47.5	20.5	19.5	33.5	13.0	17.740

Weitere Reduktionen siehe SO 41821
Sechskantmutter siehe SO 40006

Autres réductions voir SO 41821
Ecroû à six pans voir SO 40006

Alternative reductions see SO 41821
Hexagon nut see SO 40006

d=Rohraussen-ø
e=kleinste Bohrung
L=Mass in montiertem Zustand
*=mit reduziertem Klemmring

d=ø extérieur du tube
e=ø-min. de passage
L=après montage
*=avec bague de serrage de réduction

d=tube outside diameter
e=minimum bore
L=installed length
*=with reduction compression ferrule

Einstellnippel
Union orientable mâle
Adjustable male adaptor

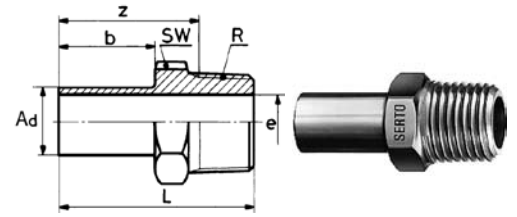

SO 41600

Type -Ad -R	Mat.-Nr.	bar	SW	L	b	z	e	kg/100
R=Rohrgewinde (kegelig)	R=Filetage-gaz BSP (conique)	R=BSP thread (tapered)						
SO 41600-A6-1/8	016.1601.100	250	12	26.0	13.0	19.5	4.0	1.000
SO 41600-A6-1/4	016.1601.110	250	14	31.0	13.0	21.0	4.0	1.950
SO 41600-A8-1/8	016.1601.160	150	12	28.0	14.0	21.5	6.0	1.200
SO 41600-A8-1/4	016.1601.170	150	14	32.0	14.0	22.3	6.0	1.800
SO 41600-A10-1/4	016.1601.270	125	14	34.0	16.0	24.3	8.0	1.650
SO 41600-A10-3/8	016.1601.280	125	17	35.0	16.0	23.9	8.0	2.900
SO 41600-A10-1/2	016.1601.285	125	22	37.0	16.0	25.8	8.0	5.570
SO 41600-A12-1/4	016.1601.380	100	14	36.0	18.0	26.3	8.0	1.750
SO 41600-A12-3/8	016.1601.390	100	17	37.0	18.0	25.9	9.0	3.000
SO 41600-A12-1/2	016.1601.400	100	22	41.0	18.0	27.8	9.0	5.670
SO 41600-A14-1/2	016.1601.504	64	22	45.0	21.0	30.8	11.0	5.650
SO 41600-A15-3/8	016.1601.532	64	17	40.0	21.0	28.9	10.5	3.200

4M

Anwendungsbeispiele:

Exemples d'utilisation:

Sample combinations:



Dieser Einstellnippel ergibt im Zusammenhang mit unserem Armaturenanschluss SO 40021 einen einstellbaren Anschluss. Nur bei Typ SO 41604-Ad-R lässt sich die Anschlussmutter auf dem zyl. Schaft so weit zurückschieben, dass eine radiale Demontage möglich ist.

Cette union montée avec un écrou SO 40021 permet d'obtenir un raccord orientable mâle. La longueur libre plus importante des pièces SO 41604-Ad-R assure le recul de l'écrou SO 40020 afin de permettre le démontage radial.

In combination with our nut connection SO 40021 this adjustable male adaptor forms an adjustable male adaptor union. Radial dismantling is possible with SO 41604-Ad-R as the nut can be fully withdrawn.

Anwendungsbeispiele:

Exemples d'utilisation:

Sample combinations:

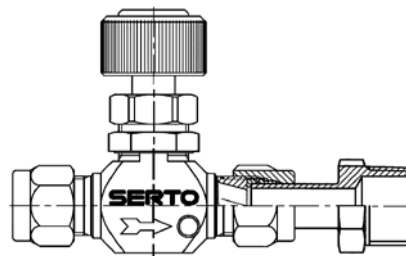
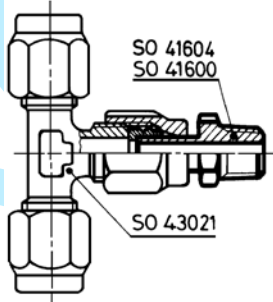

Kombiniert mit Winkel- oder T-Verschraubungen ergeben sich einstellbare Formteile.

Cette union, combinée avec un coude ou un té, permet d'obtenir des raccords orientables.

Produces adjustable configurations in combination with elbow or tee unions.

Ad=Aussen-ø der Andrehung
 e=kleinste Bohrung

Ad=ø extérieur de la portée cylindrique
 e=ø-min. de passage

Ad=outside diameter of cyl. Stub
 e=minimum bore

Einstellnippel NPT
Union orientable mâle NPT
Adjustable male adaptor NPT

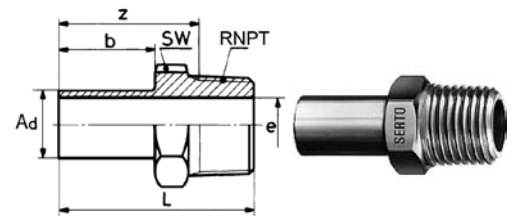

SO 41600 NPT

Type -Ad -RNPT	Mat.-Nr.	bar	SW	L	b	z	e	kg/100
RNPT=NPT Gewinde	RNPT=Filetage NPT							
						RNPT=NPT thread		
SO 41600-A6-1/8 NPT	016.1602.100	250	12	27.5	13.0	22.0	4.0	1.150
SO 41600-A6-1/4 NPT	016.1602.110	250	14	32.5	13.0	23.0	4.0	2.200
SO 41600-A8-1/8 NPT	016.1602.160	150	12	28.5	14.0	23.0	6.0	1.100
SO 41600-A8-1/4 NPT	016.1602.170	150	14	33.5	14.0	24.0	6.0	1.900
SO 41600-A10-1/4 NPT	016.1602.270	125	14	35.5	16.0	26.0	8.0	2.050
SO 41600-A10-3/8 NPT	016.1602.280	125	17	36.0	16.0	26.0	8.0	2.900
SO 41600-A10-1/2 NPT	016.1602.285	125	22	42.0	16.0	28.0	8.0	5.800
SO 41600-A12-1/4 NPT	016.1602.380	100	14	37.5	18.0	28.0	8.5	2.250
SO 41600-A12-3/8 NPT	016.1602.390	100	17	38.0	18.0	28.0	9.0	3.100
SO 41600-A12-1/2 NPT	016.1602.400	100	22	44.0	18.0	30.0	9.0	5.750
SO 41600-A14-1/2 NPT	016.1602.504	40	22	47.0	21.0	33.0	11.0	5.850
SO 41600-A15-3/8 NPT	016.1602.532	40	17	41.0	21.0	33.0	10.5	5.700
SO 41600-A15-1/2 NPT	016.1602.534	40	22	47.0	21.0	33.0	12.0	5.800

Anwendungsbeispiele:

Exemples d'utilisation:

Sample combinations:

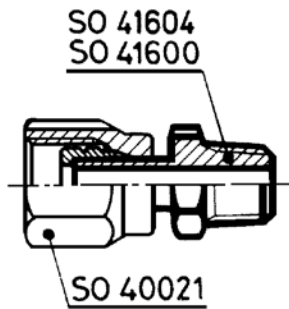

Dieser Einstellnippel ergibt im Zusammenhang mit unserem Armaturenanschluss SO 40021 einen einstellbaren Anschluss. Nur bei Typ SO 41604-Ad-R lässt sich die Anschlussmutter auf dem zyl. Schaft so weit zurückschieben, dass eine radiale Demontage möglich ist.

Cette union montée avec un écrou SO 40021 permet d'obtenir un raccord orientable mâle. La longueur libre plus importante des pièces SO 41604-Ad-R assure le recul de l'écrou SO 40020 afin de permettre le démontage radial.

In combination with our nut connection SO 40021 this adjustable male adaptor forms an adjustable male adaptor union. Radial dismantling is possible with SO 41604-Ad-R as the nut can be fully withdrawn.

Anwendungsbeispiele:

Exemples d'utilisation:

Sample combinations:

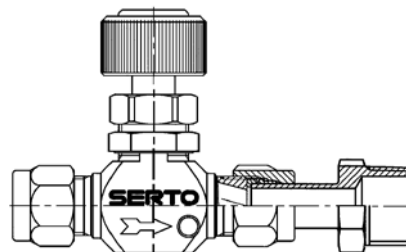
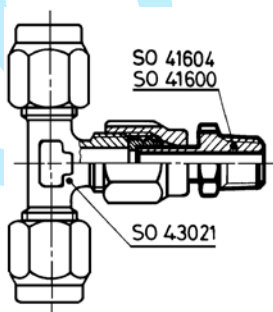

Kombiniert mit Winkel- oder T-Verschraubungen ergeben sich einstellbare Formteile.

Cette union, combinée avec un coude ou un té, permet d'obtenir des raccords orientables.

Produces adjustable configurations in combination with elbow or tee unions.

Ad=Aussen-ø der Andrehung
 e=kleinste Bohrung

Ad=ø extérieur de la portée cylindrique
 e=ø-min. de passage

Ad=outside diameter of cyl. Stub
 e=minimum bore

Einstellnippel

Union orientable mâle

Adjustable male adaptor

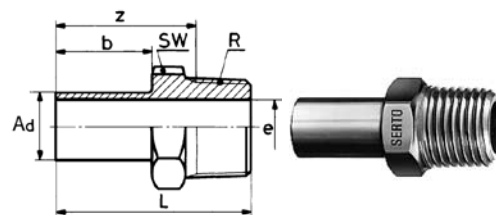

SO 41604

Type -Ad -R	Mat.-Nr.	bar	SW	L	b	z	e	kg/100
R=Rohrgewinde (kegelig) radial demontierbar	R=Filetage-gaz BSP (conique) démontable radialement					R=BSP thread (tapered) radial dismantling		
SO 41604-A15-1/2	016.1611.534	64	22	53.0	30.0	40.0	12.0	5.760
SO 41604-A15-3/4	016.1611.536	64	27	55.5	30.0	41.0	12.0	7.800
SO 41604-A22-1	016.1611.770	40	36	66.0	36.0	49.0	18.0	16.540
SO 41604-A28-1 1/4	016.1611.860	40	46	75.5	41.5	56.5	23.0	33.860

Einstellnippel vormontiert

Embout orientable mâle monté

Adjustable male adaptor assembly

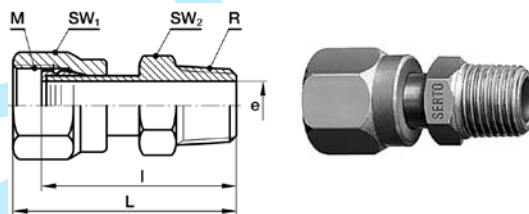

SO 41625

Type -Ad -R	Mat.-Nr.	bar	M	SW1	SW2	L	l	e	kg/100
Für metrische Rohre R=Rohrgewinde (kegelig)	Pour tubes métriques R=Filetage-gaz BSP (conique)								
SO 41625-A6-1/8	018.1621.100	250	10 x 1	12	12	34.5	27.0	4.0	1.840
SO 41625-A6-1/4	018.1621.110	250	10 x 1	14	12	39.5	32.0	4.0	2.790
SO 41625-A8-1/8	018.1621.160	150	12 x 1	12	14	37.0	29.0	6.0	2.320
SO 41625-A8-1/4	018.1621.170	150	12 x 1	14	14	41.0	33.0	6.0	2.920
SO 41625-A10-1/4	018.1621.270	125	14 x 1	14	17	45.0	35.0	8.0	3.540
SO 41625-A10-3/8	018.1621.280	125	14 x 1	17	17	46.0	36.0	8.0	6.760
SO 41625-A10-1/2	018.1621.285	125	14 x 1	22	17	48.0	38.0	8.0	7.460
SO 41625-A12-1/4	018.1621.380	100	16 x 1	14	19	48.0	37.0	8.0	4.090
SO 41625-A12-3/8	018.1621.390	100	16 x 1	17	19	49.0	38.0	9.0	5.340
SO 41625-A12-1/2	018.1621.400	100	16 x 1	22	19	53.0	42.0	9.0	8.010
SO 41625-A14-1/2	018.1621.504	40	20 x 1.5	22	24	59.0	46.5	11.0	10.210
SO 41625-A15-3/8	018.1621.532	40	20 x 1.5	17	24	54.0	41.5	10.5	7.440

4M

Einstellnippel vormontiert NPT
Embout orientable mâle montée NPT
Adjustable male adaptor assembly NPT

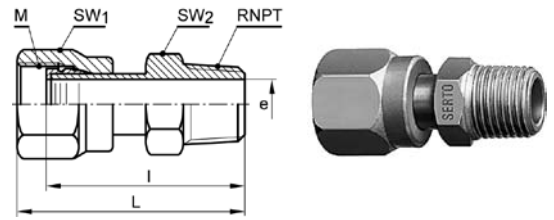

SO 41625 NPT

Type -Ad -RNPT	Mat.-Nr.	bar	M	SW1	SW2	L	l	e	kg/100
RNPT=NPT Gewinde	RNPT=Filetage NPT								
								RNPT=NPT thread	
SO 41625-A6-1/8 NPT	018.1622.100	250	10 x 1	12	12	36.0	28.5	4.0	1.700
SO 41625-A6-1/4 NPT	018.1622.110	250	10 x 1	14	12	41.0	33.5	4.0	1.750
SO 41625-A8-1/8 NPT	018.1622.160	150	12 x 1	12	14	37.5	29.5	6.0	2.250
SO 41625-A8-1/4 NPT	018.1622.170	150	12 x 1	14	14	42.5	34.5	6.0	3.020
SO 41625-A10-1/4 NPT	018.1622.270	125	14 x 1	14	17	46.5	36.5	8.0	3.940
SO 41625-A10-3/8 NPT	018.1622.280	125	14 x 1	17	17	47.0	37.0	8.0	4.790
SO 41625-A10-1/2 NPT	018.1622.285	125	14 x 1	22	17	53.0	43.0	8.0	7.690
SO 41625-A12-1/4 NPT	018.1622.380	100	16 x 1	14	19	49.5	38.5	8.0	4.590
SO 41625-A12-3/8 NPT	018.1622.390	100	16 x 1	17	19	50.0	39.0	9.0	5.440
SO 41625-A12-1/2 NPT	018.1622.400	100	16 x 1	22	19	56.0	45.0	9.0	8.090
SO 41625-A14-1/2 NPT	018.1622.504	40	20 x 1.5	22	24	61.0	48.5	11.0	10.410
SO 41625-A15-3/8 NPT	018.1622.532	40	20 x 1.5	17	24	55.0	42.5	10.5	9.940
SO 41625-A15-1/2 NPT	018.1622.534	40	20 x 1.5	22	24	61.0	48.5	12.0	10.040

Einstellnippel vormontiert
Embout orientable mâle monté
Adjustable male adaptor assembly

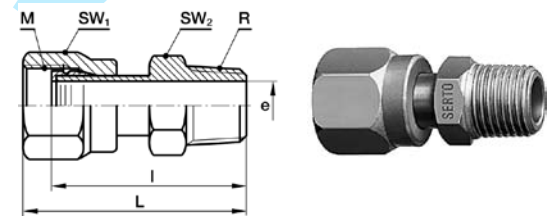

SO 41626

Type Ad -R	Mat.-Nr.	bar	M	SW1	SW2	L	l	e	kg/100
R=Rohrgewinde (kegelig) radial demontierbar	R=Filetage-gaz BSP (conique) démontable radialement								
									R=BSP thread (tapered) radial dismantling
SO 41626-A15-1/2	018.1631.534	40	20 x 1.5	22	24	68.0	55.5	12.0	10.000
SO 41626-A15-3/4	018.1631.536	40	20 x 1.5	27	24	69.5	57.0	12.0	12.040
SO 41626-A22-1	018.1631.770	25	28 x 1.5	36	32	85.0	67.5	18.0	24.960
SO 41626-A28-1 1/4	018.1631.860	16	36 x 2	46	41	97.0	77.5	23.0	50.560

M=Anschlussgewinde
 l=Einbaulänge
 e=kleinste Bohrung
 L=Mass in montiertem Zustand
 *=mit reduziertem Klemmring

M=filetage
 l=longueur encastrée
 e=ø-min. de passage
 L=après montage
 *=avec bague de serrage de réduction

M=thread
 l=fitted length
 e=minimum bore
 L=installed length
 *=with reduction compression ferrule

Einstellmuffe

Union orientable femelle

Adjustable female adaptor

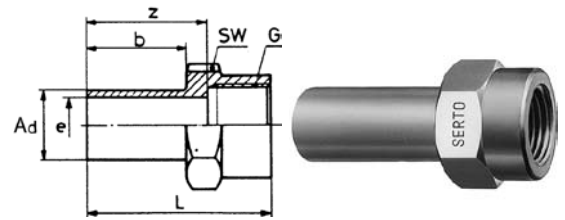

SO 41704

Type -Ad -G	Mat.-Nr.	bar	SW	L	b	z	e	kg/100
G=Rohrgewinde (zylindrisch) radial demontierbar	G=Filetage-gaz BSP (cylindrique) démontable radialement	G=BSP thread (straight) radial dismantling						
SO 41704-A12-3/8	016.1711.390	100	22	44.0	28.0	32.0	9.0	4.350
SO 41704-A12-1/2	016.1711.400	100	27	48.0	28.0	34.0	9.0	5.500
SO 41704-A15-1/2	016.1711.534	64	27	50.0	30.0	36.0	12.0	7.540
SO 41704-A15-3/4	016.1711.536	64	36	54.0	30.0	37.0	12.0	15.310
SO 41704-A22-1	016.1711.770	40	41	64.0	36.0	44.0	18.0	21.390
SO 41704-A28-1 1/4	016.1711.860	40	50	72.5	41.5	50.0	23.0	32.960

Anwendungsbeispiele:

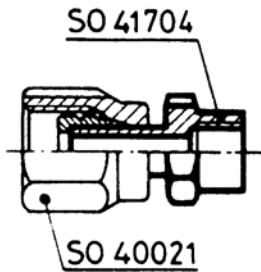

Diese Einstellmuffe ergibt im Zusammenhang mit unserem Armaturenanschluss SO 40021 einen einstellbaren Anschluss. Die Anschlussmutter lässt sich auf dem zyl. Schaft so weit zurückschieben, dass eine radiale Demontage möglich ist.

Exemples d'utilisation:



Cette union montée avec un écrou SO 40021 permet d'obtenir un raccord orientable femelle. La longueur libre plus importante assure le recul de l'écrou afin de permettre le démontage radial.

Sample combinations:

In combination with our nut connection SO 40021 this adjustable female adaptor forms an adjustable female adaptor union. Radial dismantling is possible as the nut can be fully withdrawn.

4M

Anwendungsbeispiele:

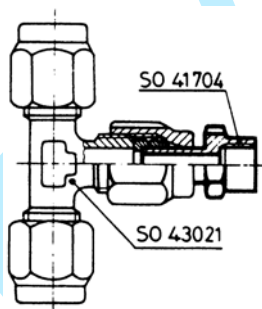

Kombiniert mit Winkel- oder T-Verschraubungen ergeben sich einstellbare Formteile.

Exemples d'utilisation:

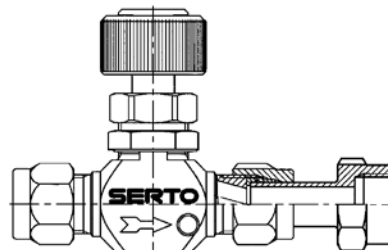

Cette union, combinée avec un coude ou un té, permet d'obtenir des raccords orientables.

Sample combinations:

Produces adjustable configurations in combination with elbow or tee unions.

Ad=Aussen-ø der Andrehung
e=kleinste Bohrung

Ad=ø extérieur de la portée cylindrique
e=ø-min. de passage

Ad=outside diameter of cyl. stub
e=minimum bore

Messing M

Laiton M

Brass M

Einstellmuffe vormontiert
Union orientable femelle montée
Adjustable female adaptor union assembly

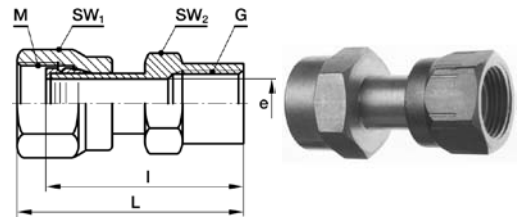

SO 41726

Type -Ad -G	Mat.-Nr.	bar	M	SW1	SW2	l	L	e	kg/100
G=Rohrgewinde (zylindrisch)	G=Filetage-gaz BSP (cylindrique)								
radial demontierbar	démontable radialement								
SO 41726-A12-3/8	018.1731.390	100	16 x 1	19	22	45.0	52.5	9.0	6.690
SO 41726-A12-1/2	018.1731.400	100	16 x 1	19	27	49.0	56.5	9.0	7.840
SO 41726-A15-1/2	018.1731.534	40	20 x 1.5	24	27	51.5	58.5	12.0	11.780
SO 41726-A15-3/4	018.1731.536	40	20 x 1.5	24	36	55.5	62.5	12.0	19.550
SO 41726-A22-1	018.1731.770	25	28 x 1.5	32	41	65.5	74.0	18.0	29.810
SO 41726-A28-1 1/4	018.1731.860	16	36 x 2	41	50	74.5	84.5	23.0	49.660

KONVAZ S!

M=Anschlussgewinde
l=Einbaulänge
e=kleinste Bohrung
L=Mass in montiertem Zustand
*=mit reduziertem Klemmring

M=filetage
l=longueur encastrée
e=ø-min. de passage
L=après montage
*=avec bague de serrage de réduction

M=thread
l=fitted length
e=minimum bore
L=installed length
*=with reduction compression ferrule

Reduktionsverschraubung

für Grundteile

Réduction

pour pièces de base

Reduced union

for basic components

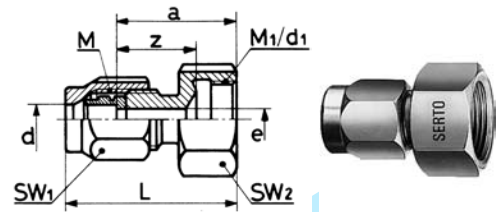

SO 41821

Type -d1 -d	Mat.-Nr.	bar	M	SW1	SW2	L	a	z	e	kg/100	
Für metrische Rohre	Pour tubes métriques			For metric tubes							
SO 41821-8-10	018.1820.083	125	14 x 1	17	17	34.0	21.0	14.0	6.5	4.310	
* SO 41821-10-4	018.1800.167	125	10 x 1	12	17	27.5	20.0	13.0	4.0	2.580	
* SO 41821-10-5	018.1800.170	125	10 x 1	12	17	27.5	20.0	13.0	4.0	2.530	
SO 41821-10-6	018.1800.175	125	10 x 1	12	17	27.5	20.0	13.0	4.0	2.470	
* SO 41821-12-6	018.1800.215	100	12 x 1	14	19	29.5	21.5	13.5	6.0	3.500	
SO 41821-12-8	018.1800.225	100	12 x 1	14	19	29.5	21.5	13.5	6.0	3.340	
* SO 41821-15-8	018.1800.400	40	14 x 1	17	24	33.5	23.5	15.5	8.0	5.920	
SO 41821-15-10	018.1800.410	40	14 x 1	17	24	33.5	23.5	15.5	8.0	5.720	
* SO 41821-18-10	018.1800.575	40	16 x 1	19	30	35.5	24.5	16.5	10.0	9.100	
SO 41821-18-12	018.1800.580	40	16 x 1	19	30	35.5	24.5	16.5	10.0	8.820	
* SO 41821-22-12	018.1800.730	25	20 x 1.5	24	36	39.0	26.5	18.5	12.0	15.140	
* SO 41821-22-13	018.1800.735	25	20 x 1.5	24	36	39.0	26.5	18.5	12.0	15.100	
SO 41821-22-14	018.1800.740	25	20 x 1.5	24	36	39.0	26.5	18.5	12.0	14.920	
SO 41821-22-15	018.1800.745	25	20 x 1.5	24	36	39.0	26.5	18.5	12.0	14.600	
* SO 41821-28-17	018.1800.868	16	28 x 1.5	32	41	50.0	32.5	22.5	19.0	25.300	
* SO 41821-28-18	018.1800.870	16	28 x 1.5	32	41	50.0	32.5	22.5	19.0	25.150	
* SO 41821-28-19	018.1800.875	16	28 x 1.5	32	41	50.0	32.5	22.5	19.0	24.840	
SO 41821-28-22	018.1800.900	16	28 x 1.5	32	41	50.0	32.5	22.5	19.0	23.620	
Für Zollrohre	Pour tubes pouces			For inch tubes							
SO 41821-10-6,35	018.1800.177	125	10 x 1	12	17	27.5	20.0	13.0	4.0	2.460	
SO 41821-15-9,52	018.1800.408	40	14 x 1	17	24	33.5	23.5	15.5	8.0	5.780	
* SO 41821-22-12,7	018.1800.732	25	20 x 1.5	24	36	39.0	26.5	18.5	12.0	15.100	

4M

Anwendungsbeispiele:

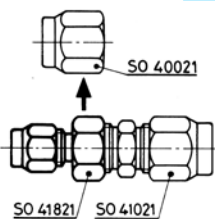

Die Reduktion SO 41821 kann an jedes SERTO Formteil mit dem passenden Gewinde (d1/M1) aufgeschraubt werden. Durch diese Kombination ergeben sich weitere Rohrreduktionen.

Dichtungsprinzip:

Bei der Montage drückt sich die Dichtkante der Reduktion in das SERTO Formteil ein, dadurch entsteht eine einwandfrei metallische Dichtung. Wir empfehlen, dass Gewinde mit einem geeigneten Flüssigklebstoff gegen unbeabsichtigtes Lösen zu sichern.

Exemples d'utilisation:

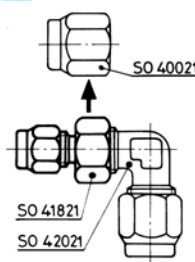

La réduction SO 41821 peut être montée sur toutes les pièces de forme SERTO avec le filetage (d1/M1) correspondant. De cette combinaison résulte d'autres réductions de tubes.

Principe d'étanchéité:

Lors du serrage, l'arête d'étanchéité de la réduction s'enfonce dans la pièce de forme SERTO et donne un joint métallique parfait. Nous recommandons de freiner le filetage avec une résine appropriée contre un desserrage intempestif.

Sample combinations:

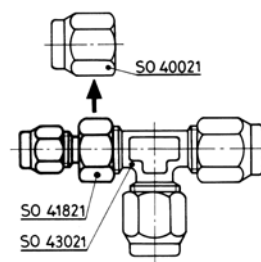

The reduction SO 41821 can be screwed onto every SERTO union body with the appropriate thread (d1/M1). From this combination result further tube reductions.

Sealing principle:

On being installed, the lip of the reduction presses into the SERTO union body, forming a sound metallic seal. We recommend to secure the thread with a suitable cement against unintended loosening.

d=Rohrassen-ø
e=kleinste Bohrung
L=Mass in montiertem Zustand
*=mit reduziertem Klemmring

d=ø extérieur du tube
e=ø-min. de passage
L=après montage
*=avec bague de serrage de réduction

d=tube outside diameter
e=minimum bore
L=installed length
*=with reduction compression ferrule

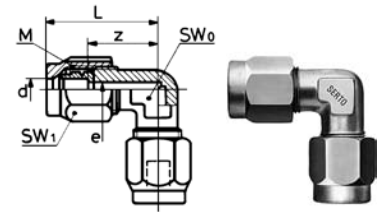
Winkelverschraubung
Coude
Elbow union

SO 42021

Type -d	Mat.-Nr.	bar	M	SW0	SW1	L	z	e	kg/100
Für metrische Rohre	Pour tubes métriques			For metric tubes					
SO 42021-2	018.2000.020	125	6 x 0.75	7	8	16.5	12.5	2.2	1.000
SO 42021-3	018.2000.030	125	6 x 0.75	7	8	18.0	13.0	2.2	1.000
SO 42021-4	018.2000.040	125	8 x 1	7	10	22.0	16.0	3.5	1.940
SO 42021-5	018.2000.050	125	8 x 1	7	10	22.5	16.0	3.5	1.920
SO 42021-6	018.2000.060	250	10 x 1	10	12	23.5	16.0	4.0	2.750
SO 42021-8	018.2000.080	150	12 x 1	10	14	26.0	18.0	6.0	3.680
SO 42021-10	018.2000.100	125	14 x 1	14	17	30.5	20.5	8.0	6.340
SO 42021-12	018.2000.120	100	16 x 1	17	19	32.5	21.5	10.0	7.200
* SO 42021-13	018.2000.130	40	20 x 1.5	19	24	36.0	23.5	13.0	13.540
SO 42021-14	018.2000.140	40	20 x 1.5	19	24	36.0	23.5	13.0	13.750
SO 42021-15	018.2000.150	40	20 x 1.5	19	24	36.0	23.5	13.0	13.110
SO 42021-16	018.2000.160	40	24 x 1.5	22	27	39.5	25.5	15.0	18.540
SO 42021-17	018.2000.170	40	24 x 1.5	22	27	39.5	25.5	15.0	18.560
SO 42021-18	018.2000.180	40	24 x 1.5	22	27	39.5	25.5	15.0	18.020
* SO 42021-19	018.2000.190	25	28 x 1.5	24	32	48.0	30.5	19.0	28.600
SO 42021-22	018.2000.220	25	28 x 1.5	27	32	48.0	30.5	19.0	26.400
SO 42021-28	018.2000.280	16	36 x 2	32	41	58.5	39.0	25.0	38.300
SO 42021-35	018.2000.350	16	42 x 2	41	50	67.5	45.0	31.0	64.600
Für Zollrohre	Pour tubes pouces			For inch tubes					
SO 42021-3,2	018.2000.032	125	6 x 0.75	7	8	18.0	13.0	2.2	0.920
SO 42021-6,35	018.2000.063	100	10 x 1	10	12	23.5	16.0	4.0	2.720
SO 42021-9,52	018.2000.095	64	14 x 1	14	17	30.5	20.5	8.0	6.460
* SO 42021-12,7	018.2000.127	40	20 x 1.5	19	24	36.0	23.5	13.0	13.540
SO 42021-15,88	018.2000.158	40	24 x 1.5	22	27	39.5	25.5	15.0	18.540

d=Rohrassen-ø
 e=kleinste Bohrung
 L=Mass in montiertem Zustand
 *=mit reduziertem Klemmring

d=ø extérieur du tube
 e=ø-min. de passage
 L=après montage
 *=avec bague de serrage de réduction

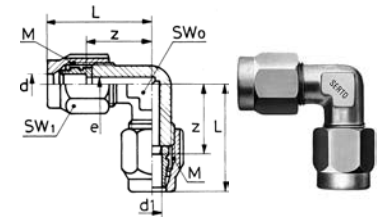
d=tube outside diameter
 e=minimum bore
 L=installed length
 *=with reduction compression ferrule

Winkelverschraubung reduziert
Coude réduite
Elbow union reduction

SO 42021 RED

Type - d - d1	Mat.-Nr.	bar	M	SW0	SW1	L	z	e	kg/100
Für metrische Rohre	Pour tubes métriques	For metric tubes							
* SO 42021-5-3	018.2004.060	125	8 x 1	7	10	22.5	16.0	3.5	2.000
* SO 42021-6-4	018.2004.110	100	10 x 1	10	12	23.5	16.0	4.0	2.860
* SO 42021-6-5	018.2004.117	100	10 x 1	10	12	23.5	16.0	4.0	2.810
* SO 42021-8-6	018.2004.140	250	12 x 1	10	14	26.0	18.0	6.0	3.740
* SO 42021-10-8	018.2004.190	150	14 x 1	14	17	30.5	20.5	8.0	6.540
* SO 42021-12-10	018.2004.240	100	16 x 1	17	19	32.5	21.5	10.0	9.000
* SO 42021-14-12	018.2004.340	40	20 x 1.5	19	24	36.0	23.5	13.0	14.130
* SO 42021-15-12	018.2004.420	40	20 x 1.5	19	24	36.0	23.5	13.0	13.650
* SO 42021-15-13	018.2004.430	40	20 x 1.5	19	24	36.0	23.5	13.0	13.540
* SO 42021-17-14	018.2004.530	40	24 x 1.5	22	27	39.5	25.5	15.0	19.270
* SO 42021-18-15	018.2004.610	40	24 x 1.5	22	27	39.5	25.5	15.0	18.720
SO 42021-18-16	018.2004.620	40	24 x 1.5	22	27	39.5	25.5	15.0	18.530
* SO 42021-22-17	018.2004.750	25	28 x 1.5	27	32	48.0	30.5	19.0	28.060
* SO 42021-22-18	018.2004.755	25	28 x 1.5	27	32	48.0	30.5	19.0	27.880
* SO 42021-22-19	018.2004.760	25	28 x 1.5	27	32	48.0	30.5	19.0	27.620
Für Zollrohre	Pour tubes pouces	For inch tubes							
SO 42021-6-6,35	018.2004.119	100	10 x 1	10	12	23.5	16.0	4.0	2.740
SO 42021-10-9,52	018.2004.197	64	14 x 1	14	17	30.5	20.5	8.0	6.450
* SO 42021-15-12,7	018.2004.427	40	20 x 1.5	19	24	36.0	23.5	13.0	13.540

Weitere Reduktionen siehe SO 41821.

Autres réductions voir So 41521

Alternative reductions see SO 41821.

d/d1=Rohraussen-ø
 e=kleinste Bohrung
 L=Mass in montiertem Zustand
 *=mit reduziertem Klemmring

d/d1=ø extérieur du tube
 e=ø-min. de passage
 L=après montage
 *=avec bague de serrage de réduction

d/d1=tube outside diameter
 e=minimum bore
 L=installed length
 *=with reduction compression ferrule

Winkelverschraubung

mit Übergangsnippel

Coude

avec adapteur mâle

Elbow union

with male adaptor

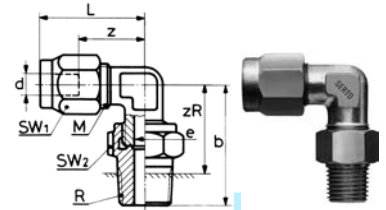

SO 42121

Type-d-R	Mat.-Nr.	bar	M	SW1	SW2	L	b	zR	z	e	kg/100
Für metrische Rohre R=Rohrgewinde (kegelig)	Pour tubes métriques R=Filetage-gaz BSP (conique)	For metric tubes R=BSP thread (tapered)									
* SO 42121-4-3/8	018.2101.068	125	10 x 1	12	17	23.5	29.0	19.0	16.0	4.0	5.040
* SO 42121-5-3/8	018.2101.086	125	10 x 1	12	17	23.5	29.0	19.0	16.0	4.0	3.990
SO 42121-6-3/8	018.2101.120	250	10 x 1	12	17	23.5	29.0	19.0	16.0	4.0	4.930
* SO 42121-10-1/2	018.2101.285	100	16 x 1	19	22	32.5	37.5	24.5	21.5	10.0	10.700
* SO 42121-13-3/4	018.2101.456	40	20 x 1.5	24	27	36.0	41.5	27.0	23.5	13.0	17.550
SO 42121-14-3/4	018.2101.506	40	20 x 1.5	24	27	36.0	41.5	27.0	23.5	13.0	17.440
SO 42121-28-1	018.2101.850	16	36 x 2	41	41	58.5	65.0	47.0	39.0	25.0	36.430
SO 42121-35-1 1/4	018.2101.944	16	42 x 2	50	50	67.5	73.0	55.0	45.0	31.0	62.000
Für Zollrohre	Pour tubes pouces	For inch tubes									
SO 42121-6,35-3/8	018.2101.145	100	10 x 1	12	17	23.5	29.0	19.0	16.0	4.0	4.920
* SO 42121-12,7-3/4	018.2101.436	40	20 x 1.5	24	27	36.0	41.5	27.0	23.5	13.0	17.550

Winkelverschraubung

mit Übergangsnippel NPT

Coude

avec adapteur mâle NPT

Elbow union

with male adaptor NPT

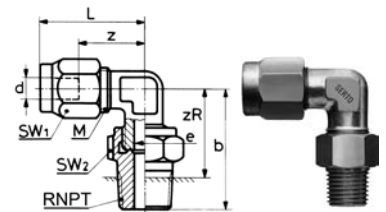

SO 42121 NPT

Type-d-R	Mat.-Nr.	bar	M	SW1	SW2	L	b	zR	z	e	kg/100
Für metrische Rohre RNPT=NPT Gewinde	Pour tubes métriques RNPT=Filetage NPT	For metric tubes RNPT=NPT thread									
* SO 42121-4-1/4 NPT	018.2102.065	125	10 x 1	12	14	23.5	32.0	22.0	16.0	4.0	4.040
* SO 42121-5-1/4 NPT	018.2102.084	125	10 x 1	12	14	23.5	32.0	22.0	16.0	4.0	3.990
SO 42121-8-1/2 NPT	018.2102.160	150	12 x 1	14	14	26.0	30.5	24.0	18.0	6.0	3.550
Für Zollrohre	Pour tubes pouces	For inch tubes									
SO 42121-6,35-1/4 NPT	018.2102.140	100	10 x 1	12	14	23.5	32.0	22.0	16.0	4.0	3.920

d=Rohraussen-ø
e=kleinste Bohrung
L=Mass in montiertem Zustand
*=mit reduziertem Klemmring

d=ø extérieur du tube
e=ø-min. de passage
L=après montage
*=avec bague de serrage de réduction

d=tube outside diameter
e=minimum bore
L=installed length
*=with reduction compression ferrule

Winkelverschraubung

mit Übergangsmuffe

Coude

avec adaptateur femelle

Elbow union

with female adaptor

SO 42221

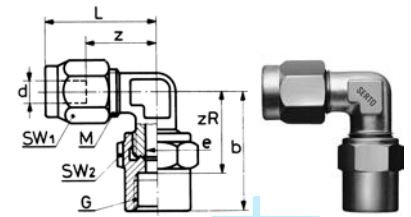

Type - d - G	Mat.-Nr.	bar	M	SW1	SW2	L	b	zR	z	e	kg/100
Für metrische Rohre G=Rohrgewinde (zylindrisch)	Pour tubes métriques G=Filetage-gaz BSP (cylindrique)	For metric tubes G=BSP thread (straight)									
* SO 42221-12-3/4	018.2201.405	64	20 x 1.5	24	32	36.0	44.0	27.0	23.5	13.0	20.390
* SO 42221-13-3/8	018.2201.450	64	20 x 1.5	24	24	36.0	39.0	27.0	23.5	13.0	14.400
* SO 42221-13-3/4	018.2201.456	64	20 x 1.5	24	32	36.0	44.0	27.0	23.5	13.0	20.280
SO 42221-14-3/8	018.2201.502	64	20 x 1.5	24	24	36.0	39.0	27.0	23.5	13.0	14.290
SO 42221-14-3/4	018.2201.506	64	20 x 1.5	24	32	36.0	44.0	27.0	23.5	13.0	20.170
SO 42221-15-3/8	018.2201.532	64	20 x 1.5	24	24	36.0	39.0	27.0	23.5	13.0	13.970
SO 42221-15-3/4	018.2201.536	64	20 x 1.5	24	32	36.0	44.0	27.0	23.5	13.0	19.850
SO 42221-28-1	018.2201.850	16	36 x 2	41	41	58.5	64.0	44.0	39.0	25.0	38.230
SO 42221-35-1 1/4	018.2201.944	16	42 x 2	50	50	67.5	72.0	50.0	45.0	31.0	62.800
Für Zollrohre	Pour tubes pouces	For inch tubes									
SO 42221-6,35-1/4	018.2201.140	100	10 x 1	12	17	23.5	30.0	19.0	16.0	5.0	4.420
* SO 42221-12,7-3/8	018.2201.432	64	20 x 1.5	24	24	36.0	39.0	27.0	23.5	13.0	14.400
* SO 42221-12,7-3/4	018.2201.436	64	20 x 1.5	24	32	36.0	44.0	27.0	23.5	13.0	20.280

4M

KONVEX

d=Rohrassens-ø
e=kleinste Bohrung
L=Mass in montiertem Zustand
*=mit reduziertem Klemmring

d=ø extérieur du tube
e=ø-min. de passage
L=après montage
*=avec bague de serrage de réduction

d=tube outside diameter
e=minimum bore
L=installed length
*=with reduction compression ferrule

Anschlusswinkel

mit Wandflansch

Coude femelle

avec applique de fixation

Female adaptor elbow union

with wall flange

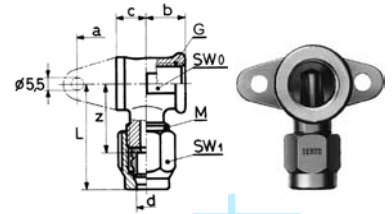

SO 42321

Type - d - G	Mat.-Nr.	bar	M	SW0	SW1	L	a	b	c	z	e	kg/100
Für metrische Rohre	Pour tubes métriques			For metric tubes								
G=Rohrgewinde (zylindrisch)	G=Filetage-gaz BSP (cylindrique)			G=BSP thread (straight)								
* SO 42321-8- ³ / ₈	018.2301.180	150	14 x 1	22	17	34.5	40.0	16.0	11.0	24.5	8.0	10.140
SO 42321-10- ³ / ₈	018.2301.280	125	14 x 1	22	17	34.5	40.0	16.0	11.0	24.5	8.0	9.940
* SO 42321-10- ¹ / ₂	018.2301.285	100	14 x 1	27	19	42.0	40.0	22.0	13.0	29.5	9.0	14.080
SO 42321-12- ³ / ₈	018.2301.390	100	16 x 1	22	19	35.5	40.0	16.0	11.0	24.5	9.0	10.160
SO 42321-12- ¹ / ₂	018.2301.400	100	16 x 1	27	19	42.0	40.0	22.0	13.0	29.5	9.0	13.800
* SO 42321-13- ¹ / ₂	018.2301.454	40	20 x 1.5	27	24	42.0	40.0	22.0	16.0	29.5	13.0	16.230
SO 42321-14- ¹ / ₂	018.2301.504	40	20 x 1.5	27	24	42.0	40.0	22.0	16.0	29.5	13.0	16.120
SO 42321-15- ¹ / ₂	018.2301.534	40	20 x 1.5	27	24	42.0	40.0	22.0	16.0	29.5	13.0	15.800
Für Zollrohre	Pour tubes pouces			For inch tubes								
* SO 42321-9,52- ³ / ₈	018.2301.235	64	14 x 1	22	17	34.5	40.0	16.0	11.0	24.5	8.0	10.000
* SO 42321-12,7- ¹ / ₂	018.2301.434	40	20 x 1.5	27	24	42.0	40.0	22.0	16.0	29.5	13.0	16.230

Weitere Anschlusswinkel siehe Winkel mit Übergangsmuffe SO 42221 und SO 42521.

Autres coudes femelles voir coude avec adaptateur femelle SO 42221 et SO 42521.

Alternative elbow with female adaptor see SO 42221 and SO 42521.

d=Rohraussen-ø
e=kleinste Bohrung
L=Mass in montiertem Zustand
*=mit reduziertem Klemmring

d=ø extérieur du tube
e=ø-min. de passage
L=après montage
*=avec bague de serrage de réduction

d=tube outside diameter
e=minimum bore
L=installed length
*=with reduction compression ferrule

Einschraubwinkel

Coude mâle

Male adaptor elbow union

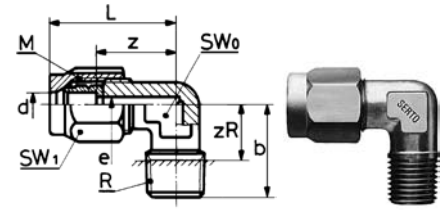

SO 42421

Type -d-R	Mat.-Nr.	bar	M	SW0	SW1	L	b	zR	z	e	kg/100
Für metrische Rohre R=Rohrgewinde (kegelig)	Pour tubes métriques R=Filetage-gaz BSP (conique)	For metric tubes R=BSP thread (tapered)									
* SO 42421-3-1/8	018.2401.040	125	8 x 1	7	10	22.5	17.5	11.0	16.0	3.0	1.600
SO 42421-4-1/8	018.2401.060	125	8 x 1	7	10	22.0	17.5	11.0	16.0	3.0	1.560
* SO 42421-4-1/4	018.2401.065	100	10 x 1	10	12	25.5	22.5	13.0	18.0	4.0	3.000
SO 42421-5-1/8	018.2401.082	125	8 x 1	7	10	22.5	17.5	11.0	16.0	3.0	1.540
* SO 42421-5-1/4	018.2401.084	100	10 x 1	10	12	25.5	22.5	13.0	18.0	4.0	2.940
SO 42421-6-1/8	018.2401.100	250	10 x 1	10	12	23.5	18.5	12.0	16.0	4.0	2.150
SO 42421-6-1/4	018.2401.110	250	10 x 1	10	12	23.5	22.5	13.0	18.0	4.0	2.880
SO 42421-8-1/8	018.2401.160	150	12 x 1	10	14	26.0	18.0	11.5	18.0	6.0	2.540
SO 42421-8-1/4	018.2401.170	150	12 x 1	10	14	26.0	22.5	13.0	18.0	6.0	3.090
* SO 42421-8-3/8	018.2401.180	150	14 x 1	14	17	30.5	25.0	15.0	20.5	8.0	5.310
SO 42421-10-1/4	018.2401.270	125	14 x 1	14	17	30.5	25.0	15.5	20.5	8.0	4.640
SO 42421-10-3/8	018.2401.280	125	14 x 1	14	17	30.5	25.0	15.0	20.5	8.0	5.110
* SO 42421-10-1/2	018.2401.285	100	16 x 1	19	19	34.0	29.5	16.5	23.0	10.0	9.020
SO 42421-12-1/4	018.2401.380	100	16 x 1	17	19	32.5	26.0	16.5	21.5	8.0	8.480
SO 42421-12-3/8	018.2401.390	100	16 x 1	17	19	32.5	26.0	16.0	21.5	10.0	6.120
SO 42421-12-1/2	018.2401.400	100	16 x 1	19	19	34.0	29.5	16.5	23.0	10.0	8.710
* SO 42421-13-1/2	018.2401.454	40	20 x 1.5	19	24	36.0	29.5	16.5	23.5	13.0	10.380
SO 42421-14-3/8	018.2401.502	40	20 x 1.5	19	24	36.0	27.0	16.0	23.5	12.0	7.570
SO 42421-14-1/2	018.2401.504	40	20 x 1.5	19	24	36.0	29.5	16.5	23.5	13.0	10.270
* SO 42421-14-3/4	018.2401.506	64	24 x 1.5	22	27	39.5	31.5	17.0	25.5	15.0	16.100
SO 42421-15-3/8	018.2401.532	40	20 x 1.5	19	24	36.0	27.0	16.0	23.5	12.0	7.350
SO 42421-15-1/2	018.2401.534	40	20 x 1.5	19	24	36.0	29.5	16.5	23.5	13.0	9.950
* SO 42421-15-3/4	018.2401.536	40	24 x 1.5	22	27	39.0	31.5	18.5	25.5	15.0	15.900
SO 42421-16-1/2	018.2401.566	40	24 x 1.5	22	27	39.5	31.5	18.5	25.5	15.0	13.040
SO 42421-16-3/4	018.2401.568	40	24 x 1.5	22	27	39.5	31.5	17.0	25.5	15.0	15.670
SO 42421-17-1/2	018.2401.596	40	24 x 1.5	22	27	39.5	31.5	18.5	25.5	15.0	12.790
SO 42421-17-3/4	018.2401.598	40	24 x 1.5	22	27	39.5	31.5	17.0	25.5	15.0	15.420
SO 42421-18-1/2	018.2401.646	40	24 x 1.5	22	27	39.5	31.5	18.5	25.5	15.0	12.520
SO 42421-18-3/4	018.2401.648	40	24 x 1.5	22	27	39.5	31.5	17.0	25.5	15.0	15.150
* SO 42421-19-3/4	018.2401.678	25	28 x 1.5	24	32	48.0	35.5	21.0	30.5	19.0	19.600
SO 42421-22-3/4	018.2401.768	25	28 x 1.5	27	32	48.0	35.5	21.0	30.5	19.0	18.500

4M

Für Zollrohre

Pour tubes pouces

For inch tubes

SO 42421-6,35-1/8	018.2401.135	100	10 x 1	10	12	23.5	18.5	12.0	16.0	4.0	2.140
SO 42421-6,35-1/4	018.2401.140	100	10 x 1	10	12	23.5	22.5	13.0	18.0	4.0	2.870
SO 42421-9,52-1/4	018.2401.230	64	14 x 1	14	17	30.5	25.0	15.5	20.5	8.0	4.700
SO 42421-9,52-3/8	018.2401.235	64	14 x 1	14	17	30.5	25.0	15.0	20.5	8.0	5.170
* SO 42421-12,7-1/2	018.2401.434	40	20 x 1.5	19	24	36.0	29.5	16.5	23.5	13.0	10.380
SO 42421-15,88-1/2	018.2401.541	40	24 x 1.5	22	27	39.5	31.5	18.5	25.5	15.0	13.040

Weitere Einschraubwinkel siehe Winkel mit Übergangsnippel SO 42121.

Autres coudes mâles femelles voir coude avec adaptateur mâle SO 42121.

Alternative elbow union with male adaptor see SO 42121.

d=Rohrassen-ø
e=kleinste Bohrung
L=Mass in montiertem Zustand
*=mit reduziertem Klemmring

d=ø extérieur du tube
e=ø-min. de passage
L=après montage
*=avec bague de serrage de réduction

d=tube outside diameter
e=minimum bore
L=installed length
*=with reduction compression ferrule

Einschraubwinkel NPT

Coude mâle NPT

Male adaptor elbow union NPT

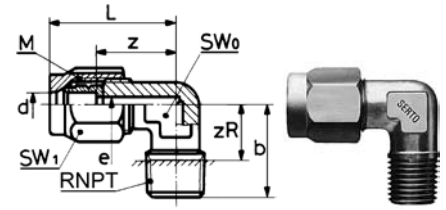

SO 42421 NPT

Type -d -RNPT	Mat.-Nr.	bar	M	SW0	SW1	L	b	zR	z	e	kg/100
Für metrische Rohre RNPT=NPT Gewinde	Pour tubes métriques RNPT=Filetage NPT			For metric tubes RNPT=NPT thread							
* SO 42421-3-1/8 NPT	018.2402.040	125	8 x 1	7	10	22.5	17.0	10.5	16.0	3.0	1.550
SO 42421-4-1/8 NPT	018.2402.060	125	8 x 1	7	10	22.0	17.0	10.5	16.0	3.0	1.510
SO 42421-5-1/8 NPT	018.2402.082	125	8 x 1	7	10	22.5	17.0	10.5	16.0	3.0	1.490
SO 42421-6-1/8 NPT	018.2402.100	250	10 x 1	10	12	23.5	17.5	11.0	16.0	4.0	2.020
* SO 42421-6-1/4 NPT	018.2402.110	250	12 x 1	10	14	26.0	22.5	12.5	18.0	6.0	3.260
SO 42421-8-1/4 NPT	018.2402.170	150	12 x 1	10	14	26.0	22.5	12.5	18.0	6.0	3.100
* SO 42421-8-3/8 NPT	018.2402.180	150	14 x 1	14	17	32.5	26.0	15.5	21.5	8.0	5.100
SO 42421-10-1/4 NPT	018.2402.270	125	14 x 1	14	17	30.5	25.0	15.0	20.5	8.0	4.610
SO 42421-10-3/8 NPT	018.2402.280	125	14 x 1	14	17	32.5	26.0	15.5	21.5	8.0	4.900
SO 42421-10-1/2 NPT	018.2402.285	125	16 x 1	19	19	34.0	29.5	16.0	23.0	10.0	9.050
SO 42421-12-3/8 NPT	018.2402.390	100	16 x 1	17	19	32.5	26.0	15.5	21.5	10.0	6.100
SO 42421-12-1/2 NPT	018.2402.400	100	16 x 1	19	19	34.0	29.5	16.0	23.0	10.0	8.700

Für Zollrohre

Pour tubes pouces

For inch tubes

SO 42421-6,35-1/8 NPT	018.2402.135	100	10 x 1	10	12	23.5	17.5	11.0	16.0	4.0	2.010
SO 42421-9,52-1/4 NPT	018.2402.230	64	14 x 1	14	17	30.5	25.0	15.0	20.5	8.0	4.670
SO 42421-9,52-3/8 NPT	018.2402.235	64	14 x 1	14	17	32.5	26.0	15.5	21.5	8.0	4.960

Einschraubwinkel METR

Coude mâle METR

Male adaptor elbow union METR

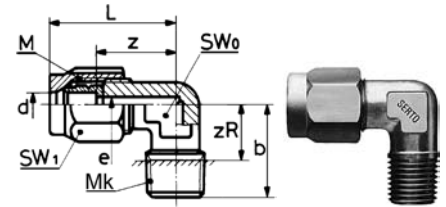

SO 42421 METR

Type -d -Mk	Mat.-Nr.	bar	M	SW0	SW1	L	b	zR	z	e	kg/100
Für metrische Rohre Mk=metrisches Gewinde (kegelig)	Pour tubes métriques Mk=Filetage métrique (conique)			For metric tubes Mk=Metric thread (tapered)							
* SO 42421-3-M8X1	018.2403.060	125	8 x 1	7	10	22.5	17.0	10.0	16.0	3.5	1.370
SO 42421-4-M8X1	018.2403.090	125	8 x 1	7	10	22.0	17.0	10.0	16.0	3.5	1.330
SO 42421-5-M8X1	018.2403.125	125	8 x 1	7	10	22.5	17.0	10.0	16.0	3.5	1.310
* SO 42421-4-M10X1	018.2403.096	125	10 x 1	10	12	23.5	17.0	10.0	16.0	4.0	2.120
* SO 42421-5-M10X1	018.2403.135	125	10 x 1	10	12	23.5	17.0	10.0	16.0	4.0	2.070
SO 42421-6-M10X1	018.2403.180	250	10 x 1	10	12	23.5	17.0	10.0	16.0	4.0	2.010

Für Zollrohre

Pour tubes pouces

For inch tubes

SO 42421-6,35-M10X1	018.2403.210	100	10 x 1	10	12	23.5	17.0	10.0	16.0	4.0	2.000
---------------------	--------------	-----	--------	----	----	------	------	------	------	-----	-------

Weitere Einschraubwinkel siehe Winkel mit Übergangsnippel SO 42121.

Autres coude mâles femelles voir coude avec adaptateur mâle SO 42121.

Alternative elbow union with male adaptor see SO 42121.

d=Rohrassens-ø
e=kleinste Bohrung
L=Mass in montiertem Zustand
*=mit reduziertem Klemmring

d=ø extérieur du tube
e=ø-min. de passage
L=après montage
*=avec bague de serrage de réduction

d=tube outside diameter
e=minimum bore
L=installed length
*=with reduction compression ferrule

Einschraubwinkel

Coude mâle

Male adaptor elbow union

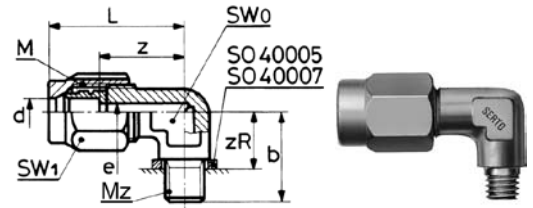

SO 42424

Type -d -Mz	Mat.-Nr.	bar	M	SW0	SW1	L	b	zR	z	e	kg/100
Für metrische Rohre	Pour tubes métriques		For metric tubes								
Mz=metrisches Gewinde (zylindrisch)	Mz=Filetage métrique (cylindrique)		Mz=Metric thread (straight)								
SO 42424-2-M5	018.2443.020	125	6 x 0.75	7	8	16.5	12.0	8.5	12.5	2.2	0.770
SO 42424-3-M5	018.2443.050	125	6 x 0.75	7	8	18.0	12.0	8.5	13.0	2.2	0.810
* SO 42424-3-M6X0,75	018.2443.055	125	8 x 1	7	10	22.5	14.0	9.5	16.0	2.5	1.260
SO 42424-4-M5	018.2443.080	125	8 x 1	7	10	22.0	12.5	9.0	16.0	2.2	1.170
SO 42424-4-M6X0,75	018.2443.085	125	8 x 1	7	10	22.0	14.0	9.5	16.0	2.5	1.220
SO 42424-5-M5	018.2443.110	125	8 x 1	7	10	22.5	12.5	9.0	16.0	2.2	1.150
SO 42424-5-M6X0,75	018.2443.115	125	8 x 1	7	10	22.5	14.0	9.5	16.0	2.5	1.200

Die entsprechende Dichtung SO 40007/ SO 40507 ist separat zu bestellen. Weitere Einschraubwinkel siehe Winkel mit Übergangsnippel SO 42121.

Le joint correspondant SO 40007/SO 40507 doit être commandé séparément. Autres coudes mâles voir coude avec adaptateur mâle SO 42121.

The appropriate washer SO 40007/ SO 40507 is to be ordered separately. Alternative elbow union with male adaptor SO 42121.



KONVEX

d=Rohrassen-ø
e=kleinste Bohrung
L=Mass in montiertem Zustand
*=mit reduziertem Klemmring

d=ø extérieur du tube
e=ø-min. de passage
L=après montage
*=avec bague de serrage de réduction

d=tube outside diameter
e=minimum bore
L=installed length
*=with reduction compression ferrule

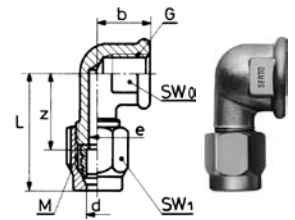
Winkel-Aufschraubverschraubung
Coude femelle
Female adaptor elbow union

SO 42521

Type -d-G	Mat.-Nr.	bar	M	SW1	SW0	L	z	b	e	kg/100
Für metrische Rohre G=Rohrgewinde (zylindrisch)	Pour tubes métriques G=Filetage-gaz BSP (cylindrique)	For metric tubes G=BSP thread (straight)								
* SO 42521-3-1/8	018.2501.040	125	8 x 1	10	14	26.5	20.0	11.5	3.5	2.250
SO 42521-4-1/8	018.2501.060	125	8 x 1	10	14	26.0	20.0	11.5	3.5	2.220
SO 42521-5-1/8	018.2501.082	125	8 x 1	10	14	26.5	20.0	11.5	3.5	2.190
SO 42521-6-1/8	018.2501.100	250	10 x 1	12	14	27.5	20.0	11.5	4.0	2.600
* SO 42521-6-1/4	018.2501.110	250	12 x 1	14	19	31.5	23.5	13.5	6.0	4.460
SO 42521-8-1/4	018.2501.170	150	12 x 1	14	19	31.5	23.5	13.5	6.0	4.300
* SO 42521-8-3/8	018.2501.180	150	14 x 1	17	22	34.5	24.5	16.0	8.0	6.590
SO 42521-10-3/8	018.2501.280	125	14 x 1	17	22	34.5	24.5	16.0	8.0	6.390
SO 42521-12-3/8	018.2501.390	100	16 x 1	19	22	35.5	24.5	16.0	9.0	6.860
* SO 42521-12-1/2	018.2501.400	40	20 x 1.5	24	27	42.0	29.5	22.0	13.0	12.950
* SO 42521-13-1/2	018.2501.454	40	20 x 1.5	24	27	42.0	29.5	22.0	13.0	12.840
SO 42521-14-1/2	018.2501.504	40	20 x 1.5	24	27	42.0	29.5	22.0	13.0	12.730
SO 42521-15-1/2	018.2501.534	40	20 x 1.5	24	27	42.0	29.5	22.0	13.0	12.410
* SO 42521-15-3/4	018.2501.536	40	24 x 1.5	27	32	47.0	33.0	24.0	15.0	19.160
SO 42521-16-1/2	018.2501.566	40	24 x 1.5	27	27	44.0	30.0	22.0	15.0	16.350
SO 42521-16-3/4	018.2501.568	40	24 x 1.5	27	32	47.0	33.0	24.0	15.0	18.930
SO 42521-17-1/2	018.2501.596	40	24 x 1.5	27	27	44.0	30.0	22.0	15.0	16.100
SO 42521-17-3/4	018.2501.598	40	24 x 1.5	27	32	47.0	33.0	24.0	15.0	18.680
SO 42521-18-1/2	018.2501.646	40	24 x 1.5	27	27	44.0	30.0	22.0	15.0	15.830
SO 42521-18-3/4	018.2501.648	40	24 x 1.5	27	32	47.0	33.0	24.0	15.0	18.410
* SO 42521-19-3/4	018.2501.678	25	28 x 1.5	32	32	51.0	33.5	24.0	19.0	22.360
SO 42521-22-3/4	018.2501.768	25	28 x 1.5	32	32	51.0	33.5	24.0	19.0	20.960
Für Zollrohre	Pour tubes pouces	For inch tubes								
SO 42521-6,35-1/8	018.2501.135	100	10 x 1	12	14	27.5	20.0	11.5	4.0	2.590
SO 42521-9,52-3/8	018.2501.235	64	14 x 1	17	22	34.5	24.5	16.0	8.0	6.450
* SO 42521-12,7-1/2	018.2501.434	40	20 x 1.5	24	27	42.0	29.5	22.0	13.0	12.840

Weitere Anschlusswinkel siehe Winkel mit Übergangsmuffe SO 42221 und SO 42321

Autres coudes femelles voir coude avec adaptateur femelle SO 42221 et SO 42321

Alternative elbow union with female adaptor see SO 42221 and SO 42321

d=Rohrassens-ø
e=kleinste Bohrung
L=Mass in montiertem Zustand
*=mit reduziertem Klemmring

d=ø extérieur du tube
e=ø-min. de passage
L=après montage
*=avec bague de serrage de réduction

d=tube outside diameter
e=minimum bore
L=installed length
*=with reduction compression ferrule

Einstellwinkel Coude orientable Adjustable elbow union

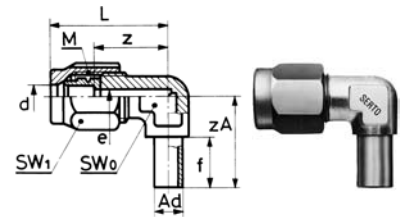

SO 42621

Type -d -Ad	Mat.-Nr.	bar	M	SW0	SW1	L	f	zA	z	e	kg/100
Für metrische Rohre	Pour tubes métriques	For metric tubes									
* SO 42621-4-A6	018.2600.045	100	10 x 1	10	12	23.5	11.0	17.5	16.0	4.0	1.980
* SO 42621-5-A6	018.2600.053	100	10 x 1	10	12	23.5	11.0	17.5	16.0	4.0	1.930
SO 42621-6-A6	018.2600.060	250	10 x 1	10	12	23.5	11.0	17.5	16.0	4.0	1.870
* SO 42621-6-A8	018.2600.063	150	12 x 1	10	14	26.0	12.0	21.0	18.0	6.0	2.600
SO 42621-8-A8	018.2600.080	150	12 x 1	10	14	26.0	12.0	21.0	18.0	6.0	2.460
* SO 42621-8-A10	018.2600.083	125	14 x 1	14	17	30.5	14.0	24.0	20.5	8.0	4.180
SO 42621-10-A10	018.2600.100	125	14 x 1	14	17	30.5	14.0	24.0	20.5	8.0	3.990
* SO 42621-10-A12	018.2600.103	100	16 x 1	17	19	32.5	15.0	25.5	21.5	9.0	5.780
SO 42621-12-A12	018.2600.120	100	16 x 1	17	19	32.5	15.0	25.5	21.5	9.0	5.500
* SO 42621-13-A15	018.2600.135	40	20 x 1.5	19	24	36.0	15.5	28.5	23.5	12.0	8.980
SO 42621-14-A15	018.2600.143	40	20 x 1.5	19	24	36.0	15.5	28.5	23.5	12.0	8.870
SO 42621-15-A15	018.2600.150	40	20 x 1.5	19	24	36.0	15.5	28.5	23.5	12.0	8.550
* SO 42621-15-A18	018.2600.156	40	24 x 1.5	22	27	39.5	18.0	33.5	25.5	15.0	13.280
SO 42621-16-A18	018.2600.165	40	24 x 1.5	22	27	39.5	18.0	33.5	25.5	15.0	13.050
SO 42621-17-A18	018.2600.173	40	24 x 1.5	22	27	39.5	18.0	33.5	25.5	15.0	12.800
SO 42621-18-A18	018.2600.180	40	24 x 1.5	22	27	39.5	18.0	33.5	25.5	15.0	12.530
* SO 42621-19-A22	018.2600.195	25	28 x 1.5	24	32	48.0	21.0	38.0	30.5	19.0	17.850
SO 42621-22-A22	018.2600.220	25	28 x 1.5	27	32	48.0	21.0	38.0	30.5	19.0	16.750
SO 42621-28-A28	018.2600.280	16	36 x 2	32	41	58.5	23.0	39.0	39.0	25.0	33.000
SO 42621-35-A35	018.2600.350	16	42 x 2	41	50	67.5	26.0	48.5	45.0	31.0	56.600

Für Zollrohre	Pour tubes pouces	For inch tubes									
SO 42621-6,35-A6	018.2600.067	100	10 x 1	10	12	23.5	11.0	17.5	16.0	4.0	1.870
SO 42621-9,52-A10	018.2600.090	64	14 x 1	14	17	30.5	14.0	24.0	20.5	8.0	3.050
* SO 42621-12,7-A15	018.2600.125	40	20 x 1.5	19	24	36.0	15.5	28.5	23.5	12.0	8.980
SO 42621-15,88-A18	018.2600.163	40	24 x 1.5	22	27	39.5	18.0	33.5	25.5	15.0	13.050

Anwendungsbeispiele:

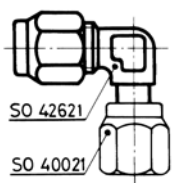

Exemples d'utilisation:

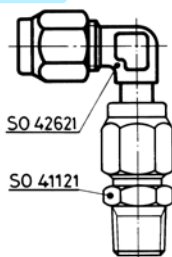

Sample combinations:

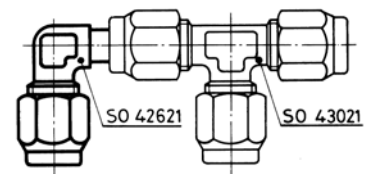

Der Einstellwinkel SO 42621 ergibt im Zusammenhang mit unserem Armaturenanschluss SO 40021 einen einstellbaren Winkelanschluss. Gegenüber dem Einschraubwinkel lässt sich diese Kombination einfacher einstellen, da Einschrauben und Ausrichten getrennt voneinander vorgenommen werden.

L'assemblage du SO 42621 et d'un écrou SO 40021 donne un coude orientable. Par rapport au coude mâle, cette combinaison permet un positionnement plus facile, car l'emboîtement et l'alignement s'ajustent séparément.

In combination with our nut connection SO 40021 this elbow forms an adjustable female adaptor elbow. In contrast to the simple male adaptor elbow union, this combination is easier to adjust, since screw-on and aligning are performed separately.

d=Rohrassens-ø
Ad=Aussen-ø der Andrehung
e=kleinste Bohrung
L=Mass in montiertem Zustand
*=mit reduziertem Klemmring

d=ø extérieur du tube
Ad=ø extérieur de la portée cylindrique
e=ø-min. de passage
L=après montage
*=avec bague de serrage de réduction

d=tube outside diameter
Ad=outside diameter of cyl. Stub
e=minimum bore
L=installed length
*=with reduction compression ferrule

Winkelverschraubung

mit Einstellzapfen vormontiert

Coude orientable monté

Adjustable elbow assembly

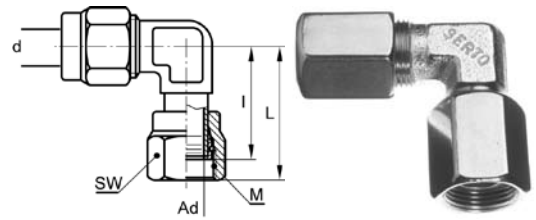
SO 42625

Type -d -Ad	Mat.-Nr.	bar	M	SW1	L	l	e	kg/100
Für metrische Rohre	Pour tubes métriques	For metric tubes						
SO 42625-4-A6	018.2620.045	100	10 x 1	12	26.0	18.5	4.0	2.820
SO 42625-5-A6	018.2620.053	100	10 x 1	12	26.0	18.5	4.0	2.770
SO 42625-6-A6	018.2620.060	250	10 x 1	12	26.0	18.5	4.0	2.710
* SO 42625-6-A8	018.2620.063	150	12 x 1	14	30.0	22.0	6.0	3.000
SO 42625-8-A8	018.2620.080	150	12 x 1	14	30.0	22.0	6.0	3.580
* SO 42625-8-A10	018.2620.083	125	14 x 1	17	35.0	25.0	8.0	6.070
SO 42625-10-A10	018.2620.100	125	14 x 1	17	35.0	25.0	8.0	5.880
* SO 42625-10-A12	018.2620.103	100	16 x 1	19	37.0	26.0	9.0	8.000
SO 42625-12-A12	018.2620.120	100	16 x 1	19	37.5	26.5	9.0	7.840
* SO 42625-13-A15	018.2620.135	40	20 x 1.5	24	42.0	30.0	12.0	13.000
SO 42625-14-A15	018.2620.143	40	20 x 1.5	24	42.0	30.0	12.0	13.000
SO 42625-15-A15	018.2620.150	40	20 x 1.5	24	42.5	30.0	12.0	12.790
* SO 42625-15-A18	018.2620.156	40	24 x 1.5	27	49.0	35.0	15.0	18.000
SO 42625-16-A18	018.2620.165	40	24 x 1.5	27	49.0	35.0	15.0	18.000
SO 42625-17-A18	018.2620.173	40	24 x 1.5	27	49.0	35.0	15.0	18.000
* SO 42625-18-A18	018.2620.180	40	24 x 1.5	27	49.0	35.0	15.0	17.790
* SO 42625-19-A22	018.2620.195	25	28 x 1.5	32	57.0	39.0	19.0	26.000
SO 42625-22-A22	018.2620.220	25	28 x 1.5	32	57.0	39.5	19.0	25.170
SO 42625-28-A28	018.2620.280	16	36 x 2	41	60.5	41.0	25.0	49.700
SO 42625-35-A35	018.2620.350	16	42 x 2	50	60.5	50.5	31.0	85.800
Für Zollrohre	Pour tubes pouces	For inch tubes						
SO 42625-6,35-A6	018.2620.067	100	10 x 1	12	26.0	18.0	4.0	2.000
SO 42625-9,52-A10	018.2620.090	64	14 x 1	17	35.0	25.0	8.0	5.000
SO 42625-12,7-A15	018.2620.125	40	20 x 1.5	24	42.0	30.0	12.0	7.000
SO 42625-15,88-A18	018.2620.163	40	24 x 1.5	27	49.0	35.0	15.0	18.000

M=Anschlussgewinde
 l=Einbaulänge
 e=kleinste Bohrung
 L=Mass in montiertem Zustand
 *=mit reduziertem Klemmring

M=filetage
 l=longueur encastrée
 e=ø-min. de passage
 L=après montage
 *=avec bague de serrage de réduction

M=thread
 l=fitted length
 e=minimum bore
 L=installed length
 *=with reduction compression ferrule

Winkel-Schottverschraubung

Durchführungslänge max. 5 mm

Coude pour passage de cloison

pour cloison max. 5 mm

Panel mount elbow union

max. panel thickness 5 mm

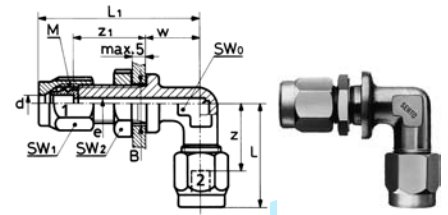

SO 42721

Type-d	Mat.-Nr.	bar	M	SW0	SW1	SW2	L	L1	w	z1	z	kg/100
Für metrische Rohre	Pour tubes métriques			For metric tubes								
* SO 42721-4	018.2700.040	100	10 x 1	10	12	14	25.5	40.5	14.0	19.0	18.0	4.270
* SO 42721-5	018.2700.050	100	10 x 1	10	12	14	25.5	40.5	14.0	19.0	18.0	4.220
SO 42721-6	018.2700.060	250	10 x 1	10	12	14	25.5	40.5	14.0	19.0	18.0	4.160
SO 42721-8	018.2700.080	150	12 x 1	11	14	17	28.5	45.0	17.0	20.0	20.5	6.480
SO 42721-10	018.2700.100	125	14 x 1	17	17	19	33.5	49.0	18.0	21.0	23.5	9.560
SO 42721-12	018.2700.120	100	16 x 1	17	19	19	34.5	50.0	18.0	21.0	23.5	10.640
* SO 42721-13	018.2700.130	40	20 x 1.5	19	24	27	38.0	56.5	20.0	24.0	25.5	18.730
SO 42721-14	018.2700.140	40	20 x 1.5	19	24	27	38.0	56.5	20.0	24.0	25.5	18.940
SO 42721-15	018.2700.150	40	20 x 1.5	19	24	27	38.0	56.5	20.0	24.0	25.5	18.300
Für Zollrohre	Pour tubes pouces			For inch tubes								
SO 42721-6,35	018.2700.063	100	10 x 1	10	12	14	25.5	40.5	14.0	19.0	18.0	4.130
SO 42721-9,52	018.2700.095	64	14 x 1	17	17	19	33.5	49.0	18.0	21.0	23.5	9.680
* SO 42721-12,7	018.2700.127	40	20 x 1.5	19	24	27	38.0	56.5	20.0	24.0	25.5	18.730

4M

KONVEX

d=Rohrassen-ø
 e=kleinste Bohrung
 L=Mass in montiertem Zustand
 *=mit reduziertem Klemmring

d=ø extérieur du tube
 e=ø-min. de passage
 L=après montage
 *=avec bague de serrage de réduction

d=tube outside diameter
 e=minimum bore
 L=installed length
 *=with reduction compression ferrule

Winkel-Schottverschraubung reduziert

Durchführungslänge max. 5 mm

Coude réduit pour passage de cloison

Pour cloison max. 5 mm

Panel mount reduction elbow union

Max. panel thickness 5 mm

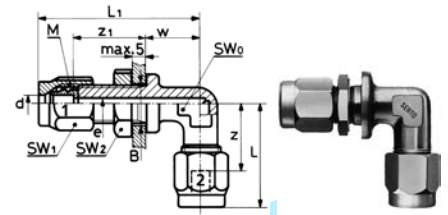

SO 42721 RED

Type -d1 -d2	Mat.-Nr.	bar	M	SW0	SW1	SW2	L	L1	w	z1	z	kg/100
Für metrische Rohre	Pour tubes métriques			For metric tubes								
* SO 42721-6-4	018.2704.110	100	10 x 1	10	12	14	25.5	40.5	14.0	19.0	18.0	4.250
* SO 42721-6-5	018.2704.117	100	10 x 1	10	12	14	25.5	40.5	14.0	19.0	18.0	4.220
* SO 42721-8-6	018.2704.140	250	12 x 1	11	14	17	28.5	45.0	17.0	20.0	20.5	6.640
* SO 42721-10-8	018.2704.190	150	14 x 1	17	17	17	33.5	49.0	18.0	21.0	23.5	9.570
* SO 42721-12-10	018.2704.240	100	16 x 1	17	19	19	34.5	50.0	18.0	21.0	23.5	10.920
* SO 42721-15-12	018.2704.420	40	20 x 1.5	19	24	27	38.5	56.6	20.0	24.5	25.5	18.840
* SO 42721-15-13	018.2704.430	40	20 x 1.5	19	24	27	38.5	56.6	20.0	24.5	25.5	18.730
SO 42721-15-14	018.2704.440	40	20 x 1.5	19	24	27	38.5	56.6	20.0	24.5	25.5	18.620
Für Zollrohre	Pour tubes pouces			For inch tubes								
SO 42721-6-6,35	018.2704.119	100	10 x 1	10	12	14	25.5	40.5	14.0	19.0	18.0	4.150
SO 42721-10-9,52	018.2704.197	64	14 x 1	17	14	17	33.5	49.0	18.0	21.0	23.5	9.620
* SO 42721-15-12,7	018.2704.427	40	20 x 1.5	19	24	27	38.5	56.5	20.0	24.5	25.5	18.730

Weitere Reduktionen siehe SO 41821
Sechskantmutter siehe SO 40006

Autres réductions voir SO 41821
Ecroû à six pans voir SO 40006

Alternative reductions see SO 41821
Hexagon nut see SO 40006

d=Rohrassen-ø
e=kleinste Bohrung
L=Mass in montiertem Zustand
*=mit reduziertem Klemmring

d=ø extérieur du tube
e=ø-min. de passage
L=après montage
*=avec bague de serrage de réduction

d=tube outside diameter
e=minimum bore
L=installed length
*=with reduction compression ferrule

Schwenkverschraubung

Coude banjo

Single banjo

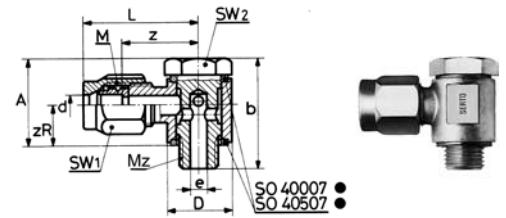

SO 42824

Type -d-G	Mat.-Nr.	bar	M	SW1	SW2	L	A	b	D	z	zR	e	kg/100
Für metrische Rohre	Pour tubes métriques			For metric tubes									
G=Rohrgewinde (zylindrisch)	G=Filetage-gaz BSP (cylindrique)			G=BSP thread (straight)									
* SO 42824-3-1/8	018.2841.040	125	8 x 1	10	14	25.0	21.0	28.0	15.0	17.3	10.0	3.8	3.710
SO 42824-4-1/8	018.2841.060	125	8 x 1	10	14	24.5	21.0	28.0	15.0	17.5	10.0	3.8	3.670
SO 42824-5-1/8	018.2841.082	125	8 x 1	10	14	25.0	21.0	28.0	15.0	17.5	10.0	3.8	3.650
SO 42824-6-1/8	018.2841.100	250	10 x 1	12	14	26.5	21.0	28.0	15.0	17.7	10.0	3.8	4.050
* SO 42824-6-1/4	018.2841.110	250	12 x 1	14	19	31.0	29.5	36.0	20.0	21.2	14.0	6.5	8.170
SO 42824-8-1/8	018.2841.160	150	12 x 1	14	14	27.5	22.5	28.0	15.0	17.7	10.5	3.8	4.420
SO 42824-8-1/4	018.2841.170	150	12 x 1	14	19	31.0	29.5	36.0	20.0	21.2	14.0	6.5	8.010
SO 42824-10-1/4	018.2841.270	125	14 x 1	17	19	33.5	29.0	36.0	20.0	21.2	13.5	6.5	8.590
* SO 42824-10-3/8	018.2841.280	100	16 x 1	19	22	36.5	31.0	39.0	25.0	22.7	15.0	8.3	13.670
SO 42824-12-3/8	018.2841.390	100	16 x 1	19	22	36.5	31.0	39.0	25.0	22.7	15.0	8.3	13.390
* SO 42824-12-1/2	018.2841.400	100	20 x 1.5	24	27	41.5	37.0	47.0	30.0	26.4	18.0	10.0	25.600
* SO 42824-13-1/2	018.2841.454	40	20 x 1.5	24	27	41.5	37.0	47.0	30.0	26.4	18.0	10.3	25.490
SO 42824-14-1/2	018.2841.504	40	20 x 1.5	24	27	41.5	37.0	47.0	30.0	26.4	18.0	10.3	25.320
SO 42824-15-1/2	018.2841.534	40	20 x 1.5	24	27	41.5	37.0	47.0	30.0	26.4	18.0	10.3	25.060
Für Zollrohre	Pour tubes pouces			For inch tubes									
SO 42824-6,35-1/8	018.2841.135	100	10 x 1	12	14	26.5	21.0	26.0	15.0	17.7	10.0	3.5	4.050
SO 42824-9,52-1/4	018.2841.230	64	14 x 1	17	19	33.5	27.0	35.0	20.0	21.2	13.0	6.3	8.590
* SO 42824-12,7-1/2	018.2841.434	40	20 x 1.5	24	27	41.5	37.0	47.0	30.0	26.4	18.0	10.3	25.490

Dichtungen werden mitgeliefert.
Ersatzdichtungen siehe SO 40007 / SO 40507.
Schwenkverschraubung mit Drossel- bzw.
Drosselrückschlagventil siehe SO 47624
und SO 47724.

Les joints sont fournis.
Joints de rechange voir
SO 40007 / SO 40507
Coude banjo à passage réglable resp. à passage
réglable et soupape de retenue voir
SO 47624 et SO 47724.

The gaskets are included.
Spare washers please see
SO 40007 / SO 40507
Single banjo with throttle valve or non-return
throttle valve please see SO 47624
and SO 47724.

d=Rohrassen-ø
e=kleinste Bohrung
L=Mass in montiertem Zustand
*=mit reduziertem Klemmring

d=ø extérieur du tube
e=ø-min. de passage
L=après montage
*=avec bague de serrage de réduction

d=tube outside diameter
e=minimum bore
L=installed length
*=with reduction compression ferrule

4M

Schwenkverschraubung METR

Coude banjo METR

Single banjo METR

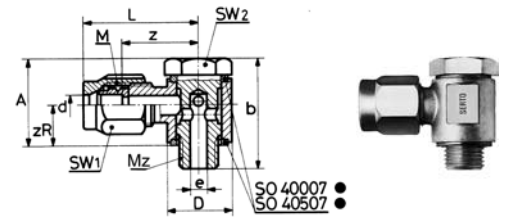

SO 42824 METR

Type -d -Mz	Mat.-Nr.	bar	M	SW1	SW2	L	A	b	D	z	zR	e	kg/100
Für metrische Rohre	Pour tubes métriques			For metric tubes									
Mz=metrisches Gewinde (zylindrisch)	Mz=Filetage métrique (cylindrique)			Mz=Metric thread (straight)									
* SO 42824-3-M5	018.2843.050	125	8 x 1	10	8	21.0	17.6	20.5	9.0	13.3	6.8	2.2	1.150
* SO 42824-3-M10X1	018.2843.065	125	8 x 1	10	14	25.0	21.0	28.0	15.0	17.3	10.5	3.8	6.410
SO 42824-4-M5	018.2843.080	125	8 x 1	10	8	20.5	17.6	20.5	9.0	13.5	6.8	2.2	1.480
SO 42824-4-M10X1	018.2843.096	125	8 x 1	10	14	24.5	21.0	28.0	15.0	17.5	10.5	3.8	6.360
SO 42824-5-M5	018.2843.110	125	8 x 1	10	8	21.0	17.6	20.5	9.0	13.5	6.8	2.2	1.470
SO 42824-5-M10X1	018.2843.135	125	8 x 1	10	14	25.0	21.0	28.0	15.0	17.5	10.5	3.8	6.350
SO 42824-6-M10X1	018.2843.180	250	10 x 1	12	14	26.5	22.5	28.0	15.0	17.7	10.5	3.8	4.010
* SO 42824-6-M12X1,5	018.2843.195	250	12 x 1	14	19	31.0	29.5	36.0	20.0	21.2	14.0	6.5	8.150
* SO 42824-6-M14X1,5	018.2843.198	250	12 x 1	14	19	31.0	29.0	36.0	20.0	21.2	14.0	3.5	8.110
SO 42824-8-M10X1	018.2843.230	150	12 x 1	14	14	27.5	22.0	28.0	15.0	17.7	10.5	3.8	4.310
SO 42824-8-M12X1,5	018.2843.240	150	12 x 1	14	19	31.0	29.5	36.0	20.0	21.2	14.0	6.5	7.990
SO 42824-8-M14X1,5	018.2843.245	150	12 x 1	14	19	31.0	29.0	36.0	20.0	21.2	14.0	6.5	7.950
SO 42824-10-M12X1,5	018.2843.275	125	14 x 1	17	19	33.5	29.5	36.0	20.0	21.2	13.5	6.5	8.720
SO 42824-10-M14X1,5	018.2843.280	125	14 x 1	17	19	31.0	29.0	36.0	20.0	21.2	13.5	6.5	8.680
Für Zollrohre	Pour tubes pouces			For inch tubes									
SO 42824-6,35-M10X1	018.2843.210	100	10 x 1	12	14	26.5	22.5	28.0	15.0	17.7	10.5	3.8	4.000
SO 42824-9,52-M12X1,5	018.2843.261	64	14 x 1	17	19	33.5	29.5	36.0	20.0	21.2	14.0	6.5	8.780
SO 42824-9,52-M14X1,5	018.2843.265	64	14 x 1	17	19	31.0	29.0	36.0	20.0	21.2	14.0	6.5	8.740

Dichtungen werden mitgeliefert.

Ersatzdichtungen siehe SO 40007 / SO 40507.

Schwenkverschraubung mit Drossel- bzw.

Drosselrückschlagventil siehe SO 47624 und SO 47724.

Les joints sont fournis.

Joint de rechange voir

SO 40007 / SO 40507

Coude banjo à passage réglable resp. à passage réglable et soupape de retenue voir SO 47624 et SO 47724.

The gaskets are included.

Spare washers please see

SO 40007 / SO 40507

Single banjo with throttle valve or non-return throttle valve please see SO 47624 and SO 47724.

d=Rohrassen-ø

e=kleinste Bohrung

L=Mass in montiertem Zustand

*=mit reduziertem Klemmring

d=ø extérieur du tube

e=ø-min. de passage

L=après montage

*=avec bague de serrage de réduction

d=tube outside diameter

e=minimum bore

L=installed length

*=with reduction compression ferrule

2-fach Winkel -Schwenkverschraubung
Coude banjo multiple
Double banjo

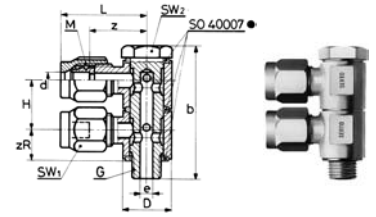

SO 42924

Type - n x d - G	Mat.-Nr.	bar	M	SW1	SW2	L	b	D	H	z	zR	e	kg/100
Für metrische Rohre G=Rohrgewinde (zylindrisch)	Pour tubes métriques G=Filetage-gaz BSP (cylindrique)	For metric tubes G=BSP thread (straight)											
* SO 42924-2X3-1/8	018.2941.040	125	8 x 1	10	14	24.0	44.5	15.0	17.0	17.5	10.0	3.8	6.290
SO 42924-2X4-1/8	018.2941.060	125	8 x 1	10	14	23.5	44.5	15.0	17.0	17.5	10.0	3.8	6.190
SO 42924-2X5-1/8	018.2941.082	125	8 x 1	10	14	24.0	44.5	15.0	17.0	17.5	10.0	3.8	6.170
SO 42924-2X6-1/8	018.2941.100	250	10 x 1	12	14	25.0	44.5	15.0	17.0	17.5	10.0	3.8	7.000
* SO 42924-2X6-1/4	018.2941.110	250	12 x 1	14	19	29.0	60.0	20.0	22.0	21.0	14.0	6.5	14.110
SO 42924-2x8-1/8	018.2941.160	150	12 x 1	14	14	25.5	44.5	15.0	17.0	17.5	10.0	3.8	7.790
SO 42924-2X8-1/4	018.2941.170	150	12 x 1	14	19	29.0	60.0	20.0	22.0	21.0	14.0	6.5	13.790
SO 42924-2X10-1/4	018.2941.270	125	14 x 1	17	19	31.0	60.0	20.0	22.0	21.0	14.0	6.5	14.990
Für Zollrohre	Pour tubes pouces	For inch tubes											
SO 42924-2X6,35-1/8	018.2941.135	100	10 x 1	12	14	25.0	44.5	15.0	17.0	17.5	10.0	3.8	7.000
SO 42924-2X9,52-1/4	018.2941.230	64	14 x 1	17	19	31.0	60.0	20.0	22.0	21.0	14.0	6.5	15.110

Dichtungen werden mitgeliefert.
Ersatzdichtungen siehe SO 40007.

Les joints sont fournis.
Joints de rechange voir SO 40007.

The gaskets are included.
Spare washers please see SO 40007.

4M

n=Anzahl Schwenkkörper
d=Rohraussen-ø
e=kleinste Bohrung
L=Mass in montiertem Zustand
*=mit reduziertem Klemmring

n=nombre d'éléments orientables
d=ø extérieur du tube
e=ø-min. de passage
L=après montage
*=avec bague de serrage de réduction

n=number of swivel bodies
d=tube outside diameter
e=minimum bore
L=installed length
*=with reduction compression ferrule

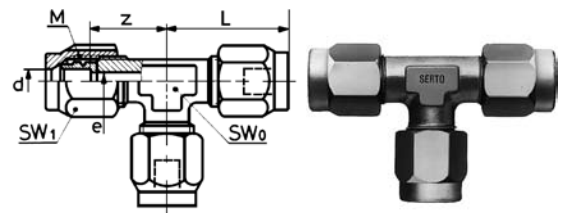
T-Verschraubung
Té
Tee union

SO 43021

Type -d	Mat.-Nr.	bar	M	SW0	SW1	L	z	e	kg/100
Für metrische Rohre	Pour tubes métriques			For metric tubes					
SO 43021-2	018.3000.020	125	6 x 0.75	7	8	16.5	12.5	2.2	1.480
SO 43021-3	018.3000.030	125	6 x 0.75	7	8	18.0	13.0	2.2	1.500
SO 43021-4	018.3000.040	125	8 x 1	10	10	22.0	16.0	3.5	2.670
SO 43021-5	018.3000.050	125	8 x 1	10	10	22.5	16.0	3.5	2.630
SO 43021-6	018.3000.060	250	10 x 1	10	12	23.5	16.0	4.0	4.240
SO 43021-8	018.3000.080	150	12 x 1	10	14	26.0	18.0	6.0	5.590
SO 43021-10	018.3000.100	125	14 x 1	14	17	30.5	20.5	8.0	8.840
SO 43021-12	018.3000.120	100	16 x 1	17	19	32.5	21.5	10.0	11.320
* SO 43021-13	018.3000.130	40	20 x 1.5	19	24	36.0	23.5	13.0	19.180
SO 43021-14	018.3000.140	40	20 x 1.5	19	24	36.0	23.5	13.0	19.710
SO 43021-15	018.3000.150	40	20 x 1.5	19	24	36.0	23.5	13.0	18.750
SO 43021-16	018.3000.160	40	24 x 1.5	22	27	39.5	25.5	15.0	27.160
SO 43021-17	018.3000.170	40	24 x 1.5	22	27	39.5	25.5	15.0	26.400
SO 43021-18	018.3000.180	40	24 x 1.5	22	27	39.5	25.5	15.0	25.600
* SO 43021-19	018.3000.190	25	28 x 1.5	27	32	48.0	30.5	19.0	41.400
SO 43021-22	018.3000.220	25	28 x 1.5	27	32	48.0	30.5	19.0	37.350
SO 43021-28	018.3000.280	16	36 x 2	32	41	58.5	39.0	25.0	44.500
SO 43021-35	018.3000.350	16	42 x 2	41	50	70.5	45.0	30.0	78.200
Für Zollrohre	Pour tubes pouces			For inch tubes					
* SO 43021-3,2	018.3000.032	125	6 x 0.75	10	10	22.0	16.0	3.5	2.700
SO 43021-6,35	018.3000.063	100	10 x 1	10	12	23.5	16.0	4.0	4.200
SO 43021-9,52	018.3000.095	64	14 x 1	14	17	30.5	20.5	8.0	9.020
* SO 43021-12,7	018.3000.127	40	20 x 1.5	19	24	36.0	23.5	13.0	19.180
SO 43021-15,88	018.3000.158	40	24 x 1.5	22	27	39.5	25.5	15.0	27.160
* SO 43021-22,2	018.3000.222	25	28 x 1.5	27	32	48.0	30.5	19.0	37.350

d=Rohrassen-ø
 e=kleinste Bohrung
 L=Mass in montiertem Zustand
 *=mit reduziertem Klemmring

d=ø extérieur du tube
 e=ø-min. de passage
 L=après montage
 *=avec bague de serrage de réduction

d=tube outside diameter
 e=minimum bore
 L=installed length
 *=with reduction compression ferrule

T-Verschraubung reduziert

Té réduit

Tee reduction union

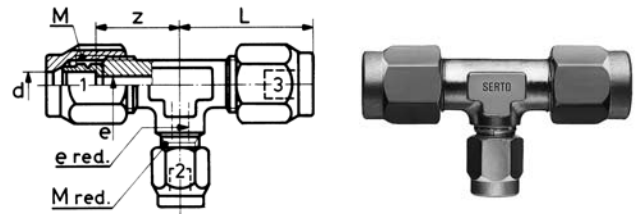

SO 43021 RED

Type -d1 -d2 -d3	Mat.-Nr.	bar	M	M red.	L	e	e red.	z	kg/100
Für metrische Rohre	Pour tubes métriques		For metric tubes						
* SO 43021-5-3-3	018.3004.030	125	8 x 1	8 x 1	22.5	3.5	3.5	16.0	2.750
* SO 43021-5-3-5	018.3004.034	125	8 x 1	8 x 1	22.5	3.5	3.5	16.0	2.690
* SO 43021-6-4-4	018.3004.046	100	10 x 1	10 x 1	23.5	4.0	4.0	16.0	4.460
* SO 43021-6-4-6	018.3004.049	100	10 x 1	10 x 1	23.5	4.0	4.0	16.0	4.350
* SO 43021-6-8-6	018.3004.058	150	12 x 1	12 x 1	26.0	6.0	6.0	18.0	5.910
SO 43021-6-10-6	018.3004.062	125	14 x 1	10 x 1	30.5	6.0	4.0	20.5	7.440
* SO 43021-8-6-6	018.3004.091	150	12 x 1	12 x 1	26.0	6.0	6.0	18.0	5.910
* SO 43021-8-6-8	018.3004.093	150	12 x 1	12 x 1	26.0	6.0	6.0	18.0	5.750
* SO 43021-8-10-8	018.3004.104	125	14 x 1	14 x 1	30.5	8.0	8.0	20.5	9.240
SO 43021-10-6-6	018.3004.143	125	14 x 1	10 x 1	30.5	8.0	4.0	20.5	7.440
SO 43021-10-6-10	018.3004.147	125	14 x 1	10 x 1	30.5	8.0	4.0	20.5	8.600
* SO 43021-10-8-10	018.3004.153	125	14 x 1	14 x 1	30.5	8.0	8.0	20.5	9.040
* SO 43021-10-10-8	018.3004.161	125	14 x 1	14 x 1	30.5	8.0	8.0	20.5	9.040
* SO 43021-10-12-10	018.3004.165	100	16 x 1	16 x 1	32.5	10.0	10.0	21.5	11.880
* SO 43021-12-6-12	018.3004.200	100	16 x 1	12 x 1	32.5	10.0	6.0	21.5	10.710
SO 43021-12-8-12	018.3004.210	100	16 x 1	12 x 1	32.5	10.0	6.0	21.5	10.540
* SO 43021-12-10-10	018.3004.220	100	16 x 1	16 x 1	32.5	10.0	10.0	21.5	11.880
* SO 43021-12-12-10	018.3004.232	100	16 x 1	16 x 1	32.5	10.0	10.0	21.5	11.600
* SO 43021-12-14-12	018.3004.246	40	20 x 1.5	20 x 1.5	36.0	13.0	13.0	23.5	20.470
* SO 43021-12-15-12	018.3004.254	40	20 x 1.5	20 x 1.5	36.0	13.0	13.0	23.5	19.830
SO 43021-14-10-10	018.3004.328	40	20 x 1.5	14 x 1	36.0	13.0	8.0	23.5	14.160
* SO 43021-14-10-12	018.3004.330	40	20 x 1.5	14 x 1	36.0	13.0	8.0	23.5	18.220
SO 43021-14-10-14	018.3004.334	40	20 x 1.5	14 x 1	36.0	13.0	8.0	23.5	17.660
* SO 43021-14-12-12	018.3004.342	40	20 x 1.5	20 x 1.5	36.0	13.0	13.0	23.5	20.470
* SO 43021-14-12-14	018.3004.346	40	20 x 1.5	20 x 1.5	36.0	13.0	13.0	23.5	20.090
SO 43021-14-14-10	018.3004.359	40	20 x 1.5	14 x 1	36.0	13.0	8.0	23.5	16.760
* SO 43021-14-14-12	018.3004.361	40	20 x 1.5	20 x 1.5	36.0	13.0	13.0	23.5	20.090
* SO 43021-14-17-14	018.3004.375	40	24 x 1.5	24 x 1.5	39.5	15.0	15.0	25.5	27.820
SO 43021-15-10-10	018.3004.403	40	20 x 1.5	14 x 1	36.0	13.0	8.0	23.5	13.770
* SO 43021-15-10-12	018.3004.405	40	20 x 1.5	14 x 1	36.0	13.0	8.0	23.5	17.800
SO 43021-15-10-15	018.3004.410	40	20 x 1.5	14 x 1	36.0	13.0	8.0	23.5	17.300
* SO 43021-15-12-12	018.3004.417	40	20 x 1.5	20 x 1.5	36.0	13.0	13.0	23.5	19.830
* SO 43021-15-12-15	018.3004.422	40	20 x 1.5	20 x 1.5	36.0	13.0	13.0	23.5	19.290
SO 43021-15-15-10	018.3004.433	40	20 x 1.5	14 x 1	36.0	13.0	8.0	23.5	16.230
* SO 43021-15-15-12	018.3004.435	40	20 x 1.5	20 x 1.5	36.0	13.0	13.0	23.5	19.290
* SO 43021-15-18-15	018.3004.447	40	24 x 1.5	24 x 1.5	39.5	13.0	15.0	25.5	27.100

4M

Weitere reduzierte T-Verschraubungen z.B. 16 mm können mit dem Klemmring SO 40001 RED oder der Reduktion SO 41821 zusammengestellt werden.

D'autres téés réduits p.ex. 16 mm peuvent s'obtenir par bague de serrage SO 40001 RED ou par réduction SO 41821.

Further tee reductions e.g. 16 mm can be produced with the ferrule SO 40001 RED or the reduction union SO 41821.

Fortsetzung nächste Seite

Suite à la prochaine page

Continued on next page

d=Rohrassen-ø
e=kleinste Bohrung
L=Mass in montiertem Zustand
*=mit reduziertem Klemmring

d=ø extérieur du tube
e=ø-min. de passage
L=après montage
*=avec bague de serrage de réduction

d=tube outside diameter
e=minimum bore
L=installed length
*=with reduction compression ferrule

T-Verschraubung reduziert

Té réduit

Tee reduction union

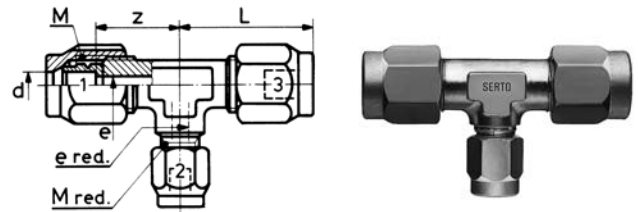

SO 43021 RED

Type -d1 -d2 -d3	Mat.-Nr.	bar	M	M red.	L	e	e red.	z	kg/100
Für metrische Rohre	Pour tubes métriques		For metric tubes						
SO 43021-15-22-15	018.3004.453	25	20 x 1.5	28 x 1.5	42.0	13.0	20.0	29.5	29.500
* SO 43021-17-10-17	018.3004.468	40	24 x 1.5	16 x 1	39.5	15.0	10.0	25.5	23.170
SO 43021-17-12-17	018.3004.480	40	24 x 1.5	16 x 1	39.5	15.0	10.0	25.5	22.850
* SO 43021-17-14-12	018.3004.494	40	24 x 1.5	16 x 1	39.5	15.0	15.0	25.5	23.450
* SO 43021-17-14-14	018.3004.498	40	24 x 1.5	24 x 1.5	39.5	15.0	15.0	25.5	27.800
* SO 43021-17-14-17	018.3004.502	40	24 x 1.5	24 x 1.5	39.5	15.0	15.0	25.5	27.400
* SO 43021-17-17-14	018.3004.518	40	24 x 1.5	24 x 1.5	39.5	15.0	15.0	25.5	27.400
* SO 43021-18-10-18	018.3004.584	40	24 x 1.5	16 x 1	39.5	15.0	10.0	25.5	22.750
SO 43021-18-12-18	018.3004.599	40	24 x 1.5	16 x 1	39.5	15.0	10.0	25.5	22.430
* SO 43021-18-15-12	018.3004.619	40	24 x 1.5	16 x 1	39.5	15.0	15.0	25.5	23.020
* SO 43021-18-15-15	018.3004.624	40	24 x 1.5	24 x 1.5	39.5	15.0	15.0	25.5	27.100
* SO 43021-18-15-18	018.3004.628	40	24 x 1.5	24 x 1.5	39.5	15.0	15.0	25.5	26.350
* SO 43021-18-18-15	018.3004.644	40	24 x 1.5	24 x 1.5	39.5	15.0	15.0	25.5	26.350
* SO 43021-22-12-22	018.3004.740	25	28 x 1.5	20 x 1.5	48.0	20.0	13.0	30.5	34.600
SO 43021-22-14-22	018.3004.784	25	28 x 1.5	20 x 1.5	48.0	20.0	13.0	30.5	34.300
SO 43021-22-15-22	018.3004.800	25	28 x 1.5	20 x 1.5	48.0	20.0	13.0	30.5	34.100
* SO 43021-22-17-22	018.3004.824	25	28 x 1.5	20 x 1.5	48.0	20.0	20.0	30.5	39.100
* SO 43021-22-18-22	018.3004.862	25	28 x 1.5	28 x 1.5	48.0	20.0	20.0	30.5	38.900
Für Zollrohre	Pour tubes pouces		For inch tubes						
SO 43021-9,52-6,35-9,52	018.3004.126	64	14 x 1	10 x 1	30.5	8.0	8.0	20.5	7.440
SO 43021-12,7-9,52-12,7	018.3004.270	40	20 x 1.5	14 x 1	36.0	13.0	8.0	23.5	17.860
SO 43021-19,05-12,7-19,05	018.3004.689	25	28 x 1.5	20 x 1.5	48.0	20.0	13.0	30.5	34.000

Weitere reduzierte T-Verschraubungen z.B. 16 mm können mit dem Klemmring SO 40001 RED oder der Reduktion SO 41821 zusammengestellt werden.

D'autres téés réduits p.ex. 16 mm peuvent s'obtenir par bague de serrage SO 40001 RED ou par réduction SO 41821.

Further tee reductions e.g. 16 mm can be produced with the ferrule SO 40001 RED or the reduction union SO 41821.

d=Rohrassen-ø
e=kleinste Bohrung
L=Mass in montiertem Zustand
*=mit reduziertem Klemmring

d=ø extérieur du tube
e=ø-min. de passage
L=après montage
*=avec bague de serrage de réduction

d=tube outside diameter
e=minimum bore
L=installed length
*=with reduction compression ferrule

T-Verschraubung

mit Übergangsnippel

Té

avec adaptateur mâle

Tee union

with male adaptor

SO 43121

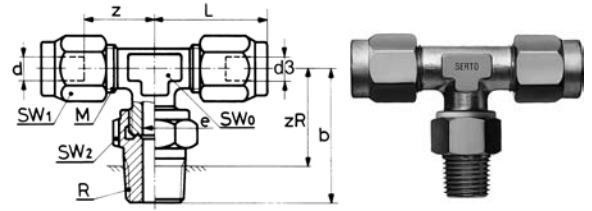

Type -d-R-d3	Mat.-Nr.	bar	M	SW0	SW1	SW2	L	b	zR	z	e	kg/100
Für metrische Rohre	Pour tubes métriques			For metric tubes								
R=Rohrgewinde (kegelig)	R=Filetage-gaz BSP (conique)			R=BSP thread (tapered)								
* SO 43121-4-3/8-4	018.3101.050	125	10 x 1	10	12	17	23.5	29.0	19.0	16.0	4.0	6.540
* SO 43121-5-3/8-5	018.3101.080	125	10 x 1	10	12	17	23.5	29.0	19.0	16.0	4.0	6.490
SO 43121-6-3/8-6	018.3101.120	250	10 x 1	10	12	17	23.5	29.0	19.0	16.0	4.0	6.430
SO 43121-8-3/8-8	018.3101.180	150	12 x 1	10	14	17	26.0	32.0	22.0	18.0	6.0	7.440
SO 43121-10-3/8-10	018.3101.280	125	14 x 1	14	17	17	30.5	34.5	24.5	20.5	8.0	9.390
* SO 43121-10-1/2-10	018.3101.290	125	16 x 1	17	19	22	32.5	37.5	24.5	21.5	10.0	14.100
SO 43121-12-1/4-12	018.3101.380	100	16 x 1	17	19	19	32.5	36.5	27.0	21.5	10.0	11.090
SO 43121-12-3/8-12	018.3101.390	100	16 x 1	17	19	19	32.5	36.5	26.5	21.5	10.0	11.850
SO 43121-12-1/2-12	018.3101.400	100	16 x 1	17	19	22	32.5	37.5	24.5	21.5	10.0	13.820
* SO 43121-13-1/2-13	018.3101.490	40	20 x 1.5	19	24	24	36.0	40.0	27.0	23.5	13.0	19.370
* SO 43121-13-3/4-13	018.3101.500	40	20 x 1.5	19	24	27	36.0	41.0	27.0	23.5	13.0	23.190
SO 43121-14-1/2-14	018.3101.540	40	20 x 1.5	19	24	24	36.0	40.0	27.0	23.5	13.0	19.580
SO 43121-14-3/4-14	018.3101.550	40	20 x 1.5	19	24	27	36.0	41.0	27.0	23.5	13.0	23.400
SO 43121-15-1/2-15	018.3101.590	40	20 x 1.5	19	24	24	36.0	40.0	27.0	23.5	13.0	18.940
SO 43121-15-3/4-15	018.3101.600	40	20 x 1.5	19	24	27	36.0	41.0	27.0	23.5	13.0	22.760
SO 43121-16-1/2-16	018.3101.630	40	24 x 1.5	22	27	30	39.5	41.0	28.0	25.5	15.0	26.860
SO 43121-16-3/4-16	018.3101.640	40	24 x 1.5	22	27	30	39.5	45.0	31.0	25.5	15.0	29.800
SO 43121-17-1/2-17	018.3101.680	40	24 x 1.5	22	27	30	39.5	43.0	30.0	25.5	15.0	26.900
SO 43121-17-3/4-17	018.3101.690	40	24 x 1.5	22	27	30	39.5	45.0	31.0	25.5	15.0	29.820
SO 43121-18-1/2-18	018.3101.730	40	24 x 1.5	22	27	30	39.5	43.0	30.0	25.5	15.0	26.330
SO 43121-18-3/4-18	018.3101.740	40	24 x 1.5	22	27	30	39.5	45.0	31.0	25.5	15.0	29.280
* SO 43121-19-3/4-19	018.3101.780	25	28 x 1.5	27	28	36	48.0	49.0	35.0	30.5	20.0	41.200
SO 43121-22-3/4-22	018.3101.830	25	28 x 1.5	27	28	36	48.0	49.0	35.0	30.5	20.0	38.500
SO 43121-28-1-28	018.3101.880	16	36 x 2	32	41	41	58.5	65.0	47.0	39.0	25.0	42.700
SO 43121-35-1 1/4-35	018.3101.920	16	42 x 2	41	50	50	67.5	73.0	55.0	45.0	31.0	75.600
Für Zollrohre	Pour tubes pouces			For inch tubes								
SO 43121-6,35-3/8-6,35	018.3101.150	100	10 x 1	10	12	17	23.5	29.0	19.0	16.0	4.0	6.420
SO 43121-9,52-3/8-9,52	018.3101.215	64	14 x 1	14	17	17	30.5	34.5	24.5	20.5	8.0	9.510
* SO 43121-12,7-1/2-12,7	018.3101.460	40	20 x 1.5	19	24	24	36.0	40.0	27.0	23.5	13.0	19.370
* SO 43121-12,7-3/4-12,7	018.3101.465	40	20 x 1.5	19	24	27	36.0	41.0	27.0	23.5	13.0	23.190

4M

d=Rohrassen-ø
e=kleinste Bohrung
L=Mass in montiertem Zustand
*=mit reduziertem Klemmring

d=ø extérieur du tube
e=ø-min. de passage
L=après montage
*=avec bague de serrage de réduction

d=tube outside diameter
e=minimum bore
L=installed length
*=with reduction compression ferrule

T-Verschraubung

mit Übergangsnippel NPT

Té

avec adaptateur mâle NPT

Tee union

with male adaptor NPT

SO 43121 NPT

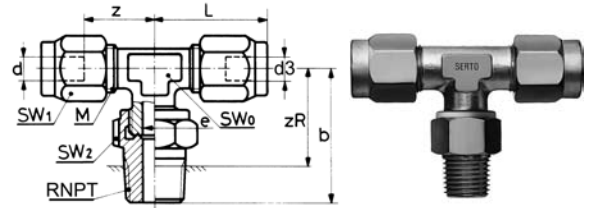

Type -d -RNPT -d3	Mat.-Nr.	bar	M	SW0	SW1	SW2	L	b	zR	z	e	kg/100
Für metrische Rohre RNPT=NPT Gewinde	Pour tubes métriques RNPT=Filetage NPT			For metric tubes RNPT=NPT thread								
* SO 43121-4-1/8 NPT-4	018.3102.040	125	10 x 1	10	12	12	23.5	28.0	21.5	16.0	4.0	4.440
* SO 43121-4-1/4 NPT-4	018.3102.045	125	10 x 1	10	12	14	23.5	32.0	22.0	16.0	4.0	5.560
* SO 43121-5-1/8 NPT-5	018.3102.070	125	10 x 1	10	12	12	23.5	28.0	21.5	16.0	4.0	4.390
* SO 43121-5-1/4 NPT-5	018.3102.075	125	10 x 1	10	12	14	23.5	32.0	22.0	16.0	4.0	5.510
SO 43121-6-1/8 NPT-6	018.3102.100	250	10 x 1	10	12	12	23.5	28.0	21.5	16.0	4.0	4.330
SO 43121-6-1/4 NPT-6	018.3102.110	250	10 x 1	10	12	14	23.5	32.0	22.0	16.0	4.0	5.450
SO 43121-8-1/8 NPT-8	018.3102.160	150	12 x 1	10	14	14	26.0	30.0	23.5	18.0	6.0	5.460
SO 43121-8-1/4 NPT-8	018.3102.170	150	12 x 1	10	14	14	26.0	34.0	24.0	18.0	6.0	6.200
SO 43121-10-1/4 NPT-10	018.3102.270	125	14 x 1	14	17	17	30.5	26.5	26.5	20.5	8.0	8.750
Für Zollrohre	Pour tubes pouces			For inch tubes								
SO 43121-6,35-1/8 NPT-6,35	018.3102.140	100	10 x 1	10	12	12	23.5	28.0	21.5	16.0	4.0	4.300
SO 43121-6,35-1/4 NPT-6,35	018.3102.145	100	10 x 1	10	12	14	23.5	32.0	22.0	16.0	4.0	5.420
SO 43121-9,52-1/4 NPT-9,52	018.3102.210	64	14 x 1	14	17	17	30.5	36.5	26.5	20.5	8.0	8.870

d=Rohrassen-ø
e=kleinste Bohrung
L=Mass in montiertem Zustand
*=mit reduziertem Klemmring

d=ø extérieur du tube
e=ø-min. de passage
L=après montage
*=avec bague de serrage de réduction

d=tube outside diameter
e=minimum bore
L=installed length
*=with reduction compression ferrule

T-Verschraubung

mit Übergangsmuffe

Té

avec pièce intermédiaire femelle

Tee union

with female adaptor

SO 43221

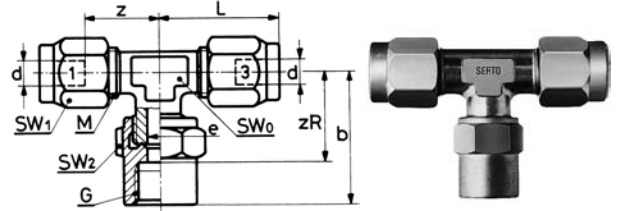

Type -d-G	Mat.-Nr.	bar	M	SW0	SW1	SW2	L	b	zR	z	e	kg/100
Für metrische Rohre	Pour tubes métriques			For metric tubes								
G=Rohrgewinde (zylindrisch)	G=Filetage-gaz BSP (cylindrique)			G=BSP thread (straight)								
* SO 43221-4-1/8-4	018.3201.040	125	10 x 1	10	12	14	23.5	29.0	19.0	16.0	4.0	5.200
* SO 43221-4-1/4-4	018.3201.045	125	10 x 1	10	12	17	23.5	30.0	19.0	16.0	4.0	6.060
* SO 43221-4-3/8-4	018.3201.050	125	10 x 1	10	12	22	23.5	31.0	19.0	16.0	4.0	8.330
* SO 43221-5-1/8-5	018.3201.070	125	10 x 1	10	12	14	23.5	29.0	19.0	16.0	4.0	5.150
* SO 43221-5-1/4-5	018.3201.075	125	10 x 1	10	12	17	23.5	30.0	19.0	16.0	4.0	6.010
* SO 43221-5-3/8-5	018.3201.080	125	10 x 1	10	12	22	23.5	31.0	19.0	16.0	4.0	8.270
SO 43221-6-1/8-6	018.3201.100	100	10 x 1	10	12	14	23.5	29.0	19.0	16.0	4.0	5.090
SO 43221-6-1/4-6	018.3201.110	100	10 x 1	10	12	17	23.5	30.0	19.0	16.0	4.0	5.950
SO 43221-6-3/8-6	018.3201.120	100	10 x 1	10	12	22	23.5	31.0	19.0	16.0	4.0	8.220
SO 43221-8-1/8-8	018.3201.160	100	12 x 1	10	14	17	26.0	31.0	21.0	18.0	4.0	7.260
SO 43221-8-1/4-8	018.3201.170	100	12 x 1	10	14	17	26.0	33.0	22.0	18.0	6.0	7.010
SO 43221-8-3/8-8	018.3201.180	100	12 x 1	10	14	22	26.0	33.0	21.0	18.0	6.0	9.250
SO 43221-10-1/4-10	018.3201.270	64	14 x 1	14	17	17	30.5	34.5	24.5	20.5	8.0	9.040
SO 43221-10-3/8-10	018.3201.280	64	14 x 1	14	17	22	30.5	36.5	24.5	20.5	8.0	11.710
* SO 43221-10-1/2-10	018.3201.290	64	16 x 1	17	19	27	32.5	38.5	24.5	21.5	10.0	16.530
SO 43221-12-3/8-12	018.3201.390	64	16 x 1	17	19	22	32.5	36.5	24.5	21.5	10.0	13.070
SO 43221-12-1/2-12	018.3201.400	64	16 x 1	17	19	27	32.5	38.5	24.5	21.5	10.0	16.250
* SO 43221-12-3/4-12	018.3201.410	40	20 x 1.5	19	24	32	36.0	44.0	27.0	23.5	13.0	26.030
* SO 43221-13-3/8-13	018.3201.480	40	20 x 1.5	19	24	24	36.0	39.0	27.0	23.5	13.0	20.040
* SO 43221-13-1/2-13	018.3201.490	40	20 x 1.5	19	24	27	36.0	41.0	27.0	23.5	13.0	22.070
* SO 43221-13-3/4-13	018.3201.500	40	20 x 1.5	19	24	32	36.0	44.0	27.0	23.5	13.0	25.920
SO 43221-14-3/8-14	018.3201.530	40	20 x 1.5	19	24	24	36.0	39.0	27.0	23.5	13.0	20.250
SO 43221-14-1/2-14	018.3201.540	40	20 x 1.5	19	24	27	36.0	41.0	27.0	23.5	13.0	22.280
SO 43221-14-3/4-14	018.3201.550	40	20 x 1.5	19	24	32	36.0	44.0	27.0	23.5	13.0	26.130
SO 43221-15-3/8-15	018.3201.580	40	20 x 1.5	19	24	24	36.0	39.0	27.0	23.5	13.0	19.610
SO 43221-15-1/2-15	018.3201.590	40	20 x 1.5	19	24	27	36.0	41.0	27.0	23.5	13.0	21.640
SO 43221-15-3/4-15	018.3201.600	40	20 x 1.5	19	24	32	36.0	44.0	27.0	23.5	13.0	25.490
SO 43221-16-1/2-16	018.3201.630	40	24 x 1.5	22	27	30	39.5	44.0	30.0	25.5	15.0	30.280
SO 43221-16-3/4-16	018.3201.640	40	24 x 1.5	22	27	32	39.5	47.0	30.0	25.5	16.0	31.220
SO 43221-17-1/2-17	018.3201.680	40	24 x 1.5	22	27	30	39.5	44.0	30.0	25.5	15.0	30.300
SO 43221-17-3/4-17	018.3201.690	40	24 x 1.5	22	27	32	39.5	47.0	30.0	25.5	15.0	31.240
SO 43221-18-1/2-18	018.3201.730	40	24 x 1.5	22	27	30	39.5	44.0	30.0	25.5	15.0	29.760
SO 43221-18-3/4-18	018.3201.740	40	24 x 1.5	22	27	32	39.5	47.0	30.0	25.5	15.0	30.700
* SO 43221-19-3/4-19	018.3201.780	25	28 x 1.5	27	28	36	48.0	51.0	34.0	30.5	20.0	46.000
SO 43221-22-3/4-22	018.3201.830	25	28 x 1.5	27	28	36	48.0	51.0	34.0	30.5	20.0	43.340
SO 43221-28-1-28	018.3201.880	16	36 x 2	32	41	41	58.5	64.0	44.0	39.0	25.0	44.500
SO 43221-35-1 1/4-35	018.3201.920	16	42 x 2	41	50	50	70.5	71.0	50.0	45.0	30.0	76.400

4M

Fortsetzung nächste Seite

Suite à la prochaine page

Continued on next page

d=Rohrassen-ø
e=kleinste Bohrung
L=Mass in montiertem Zustand
*=mit reduziertem Klemmring

d=ø extérieur du tube
e=ø-min. de passage
L=après montage
*=avec bague de serrage de réduction

d=tube outside diameter
e=minimum bore
L=installed length
*=with reduction compression ferrule

Messing M
Laiton M
Brass M

Für Zollrohre

Pour tubes pouces

For inch tubes

SO 43221-6,35- $\frac{1}{8}$ -6,35	018.3201.140	100	10 x 1	10	12	14	23.5	29.0	19.0	16.0	4.0	5.060
SO 43221-6,35- $\frac{1}{4}$ -6,35	018.3201.145	100	10 x 1	10	12	17	23.5	30.0	19.0	16.0	4.0	5.920
SO 43221-6,35- $\frac{3}{8}$ -6,35	018.3201.150	100	10 x 1	10	12	22	23.5	31.0	19.0	16.0	4.0	8.190
SO 43221-9,52- $\frac{1}{4}$ -9,52	018.3201.210	64	14 x 1	14	17	17	30.5	34.5	24.5	20.5	8.0	9.160
SO 43221-9,52- $\frac{3}{8}$ -9,52	018.3201.215	64	14 x 1	14	17	22	30.5	36.5	24.5	20.5	8.0	11.830
* SO 43221-12,7- $\frac{3}{8}$ -12,7	018.3201.455	40	20 x 1.5	19	24	24	36.0	39.0	27.0	23.5	13.0	20.040
* SO 43221-12,7- $\frac{1}{2}$ -12,7	018.3201.460	40	20 x 1.5	19	24	27	36.0	41.0	27.0	23.5	13.0	22.070
* SO 43221-12,7- $\frac{3}{4}$ -12,7	018.3201.465	40	20 x 1.5	19	24	32	36.0	44.0	27.0	23.5	13.0	25.920

KOLVAZ S.r.o.

d=Rohrussen- \varnothing
 e=kleinste Bohrung
 L=Mass in montiertem Zustand
 *=mit reduziertem Klemmring

d= \varnothing extérieur du tube
 e= \varnothing -min. de passage
 L=après montage
 *=avec bague de serrage de réduction

d=tube outside diameter
 e=minimum bore
 L=installed length
 *=with reduction compression ferrule

Einstell-T
Té orientable
Adjustable tee union

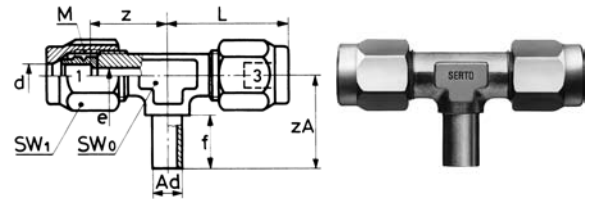

SO 43621 T

Type -d1 -Ad -d3	Mat.-Nr.	bar	M	SW0	SW1	L	f	zA	z	e	kg/100
* SO 43621-4-A6-4	018.3600.045	100	10 x 1	10	12	23.5	11.0	17.5	16.0	4.0	3.540
* SO 43621-5-A6-5	018.3600.053	100	10 x 1	10	12	23.5	11.0	17.5	16.0	4.0	3.500
SO 43621-6-A6-6	018.3600.060	250	10 x 1	10	12	23.5	11.0	17.5	16.0	4.0	3.160
* SO 43621-6-A8-6	018.3600.063	150	12 x 1	10	14	26.0	14.0	23.0	18.0	6.0	4.670
SO 43621-8-A8-8	018.3600.080	150	12 x 1	10	14	26.0	14.0	23.0	18.0	6.0	4.230
* SO 43621-8-A10-8	018.3600.083	125	14 x 1	14	17	30.5	16.0	25.5	20.5	7.5	7.940
SO 43621-10-A10-10	018.3600.100	125	14 x 1	14	17	30.5	16.0	25.5	20.5	7.5	6.970

L-Verschraubung
mit Einstellzapfen

L orientable
Adjustable L union

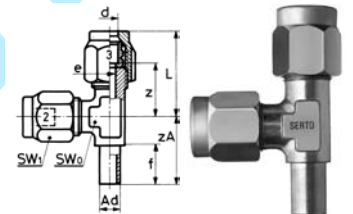

SO 43621 L

Type -Ad -d2 -d3	Mat.-Nr.	bar	M	SW0	SW1	L	f	zA	z	e	kg/100
* SO 43621-A6-4-4	018.3610.045	100	10 x 1	10	12	23.5	11.0	17.5	16.0	4.0	3.600
* SO 43621-A6-5-5	018.3610.053	100	10 x 1	10	12	23.5	11.0	17.5	16.0	4.0	3.560
SO 43621-A6-6-6	018.3610.060	250	10 x 1	10	12	23.5	11.0	17.5	16.0	4.0	3.220
* SO 43621-A8-6-6	018.3610.063	150	12 x 1	10	14	26.0	14.0	23.0	18.0	6.0	4.700
SO 43621-A8-8-8	018.3610.080	150	12 x 1	10	14	26.0	14.0	23.0	18.0	6.0	4.260
* SO 43621-A10-8-8	018.3610.083	125	14 x 1	14	17	30.5	16.0	25.5	20.5	7.5	7.970
SO 43621-A10-10-10	018.3610.100	125	14 x 1	14	17	30.5	16.0	25.5	20.5	7.5	7.000

4M

Das Einstell-T SO 43621 ergibt im Zusammenhang mit unserem Armaturenanschluss SO 40021 eine einstellbare T-Kombination.

L'assemblage du SO 43621 et d'un écrou SO 40021 donne un Té orientable.

In combination with our nut connection SO 40021 the adjustable Tee union SO 43621 forms an adjustable female adaptor Tee union.

Anwendungsbeispiele:

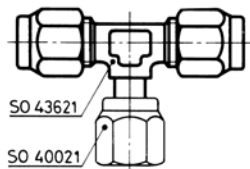

Gegenüber dem Einschraub-T lässt sich diese Kombination einfacher einstellen, da Einschrauben und Ausschrauben getrennt voneinander vorgenommen werden.

Exemples d'utilisation:

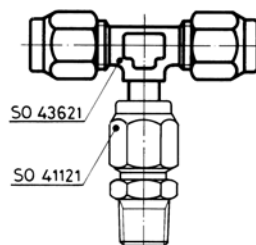

Par rapport à un Té cette combinaison permet un positionnement plus facile. L'assemblage et l'alignement se font séparément.

Sample combinations:

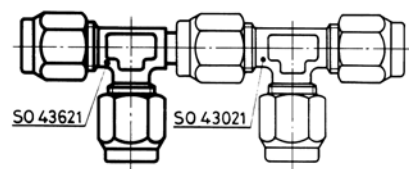

In contrast to the simple male adaptor Tee union, this combination is easier to adjust, since screw-on and aligning are performed separately.

d=Rohrassen-ø
Ad=Aussen-ø der Andrehung
e=kleinste Bohrung
L=Mass in montiertem Zustand
*=mit reduziertem Klemmring

d=ø extérieur du tube
Ad=ø extérieur de la portée cylindrique
e=ø-min. de passage
L=après montage
*=avec bague de serrage de réduction

d=tube outside diameter
Ad=outside diameter of cyl. Stub
e=minimum bore
L=installed length
*=with reduction compression ferrule

Einstellbare T-Verschraubung

vormontiert

Té orientable montée

Adjustable tee assembly

SO 43625 T

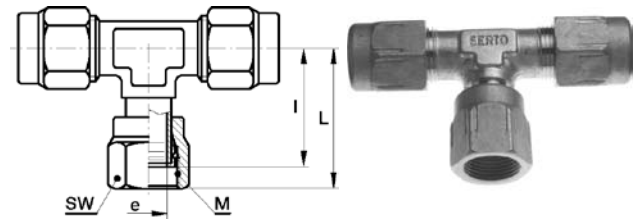

Type -d1 Ad -d3	Mat.-Nr.	bar	M	SW	l	L	e	kg/100
SO 43625-4-A6-4	018.3620.045	100	10 x 1	12	18.5	26.0	4.0	4.380
SO 43625-5-A6-5	018.3620.053	100	10 x 1	12	18.5	26.0	4.0	4.340
SO 43625-6-A6-6	018.3620.060	250	10 x 1	12	18.5	26.0	4.0	4.000
SO 43625-6-A8-6	018.3620.063	150	12 x 1	14	24.0	30.0	6.0	5.790
SO 43625-8-A8-8	018.3620.080	150	12 x 1	14	24.0	30.0	6.0	5.350
SO 43625-8-A10-8	018.3620.083	125	14 x 1	17	25.0	35.0	7.5	9.830
SO 43625-10-A10-10	018.3620.100	125	14 x 1	17	25.0	35.0	7.5	8.860

Einstellbare L-Verschraubung

vormontiert

L orientable montée

Adjustable L assembly

SO 43625 L

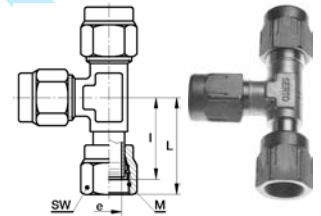

Type -Ad -d2 -d3	Mat.-Nr.	bar	M	SW	l	L	e	kg/100
SO 43625-A6-4-4	018.3630.045	100	10 x 1	12	18.5	26.0	4.0	4.400
SO 43625-A6-5-5	018.3630.053	100	10 x 1	12	18.5	26.0	4.0	4.400
SO 43625-A6-6-6	018.3630.060	250	10 x 1	12	18.5	26.0	4.0	4.060
SO 43625-A8-6-6	018.3630.063	150	12 x 1	14	22.0	30.0	6.0	5.820
SO 43625-A8-8-8	018.3630.080	150	12 x 1	14	22.0	30.0	6.0	5.380
SO 43625-A10-8-8	018.3630.083	125	14 x 1	17	25.0	35.0	7.5	9.860
SO 43625-A10-10-10	018.3630.100	125	14 x 1	17	25.0	35.0	7.5	8.890

M=Anschlussgewinde

l=Einbaulänge

e=kleinste Bohrung

L=Mass in montiertem Zustand

*=mit reduziertem Klemmring

M=filetage

l=longueur encastrée

e=ø-min. de passage

L=après montage

*=avec bague de serrage de réduction

M=thread

l=fitted length

e=minimum bore

L=installed length

*=with reduction compression ferrule

T-Einschraubverschraubung

Té mâle

Male adaptor tee union

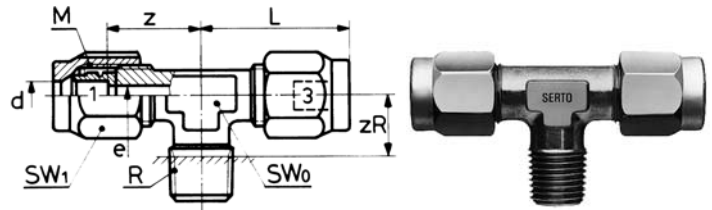

SO 43721 T

Type -d1 -R -d3	Mat.-Nr.	bar	M	SW0	SW1	L	zR	z	e	kg/100
Für metrische Rohre	Pour tubes métriques		For metric tubes							
* SO 43721-3-1/8-3	018.3701.030	125	8 x 1	7	10	22.5	10.5	16.0	3.0	2.390
SO 43721-4-1/8-4	018.3701.040	125	8 x 1	7	10	22.0	10.5	16.0	3.0	2.350
* SO 43721-4-1/4-4	018.3701.045	125	10 x 1	10	12	23.5	13.0	16.0	4.0	4.110
SO 43721-5-1/8-5	018.3701.070	125	8 x 1	7	10	22.5	10.5	16.0	3.0	2.330
* SO 43721-5-1/4-5	018.3701.075	125	10 x 1	10	12	23.5	13.0	16.0	4.0	4.060
SO 43721-6-1/8-6	018.3701.100	250	10 x 1	10	12	23.5	11.0	16.0	4.0	3.240
SO 43721-6-1/4-6	018.3701.110	250	10 x 1	10	12	23.5	13.0	18.0	4.0	4.000
SO 43721-8-1/4-8	018.3701.170	150	12 x 1	10	14	26.0	13.0	18.0	6.0	4.730
SO 43721-10-1/4-10	018.3701.270	125	14 x 1	14	17	30.5	15.5	20.5	8.0	7.900

Für Zollrohre	Pour tubes pouces	For inch tubes								
SO 43721-6,35-1/8-6,35	018.3701.140	100	10 x 1	10	12	23.5	11.0	16.0	4.0	3.210
SO 43721-6,35-1/4-6,35	018.3701.145	100	10 x 1	10	12	23.5	13.0	18.0	4.0	3.970
SO 43721-9,52-1/4-9,52	018.3701.210	64	14 x 1	14	17	30.5	15.5	20.5	8.0	7.210

Die entsprechende Dichtung ist immer separat zu bestellen. Weitere Einschraub-T siehe T-Verschraubung mit Übergangsnippel SO 43121.

Les joints correspondants sont à commander séparément. Autres Tés mâles voir Té avec adaptateur mâle SO 43121.

The relevant washer must always be ordered separately. Alternative male adaptor Tee see Tee union with male adaptor SO 43121.

T-Einschraubverschraubung

Té mâle

Male adaptor tee union

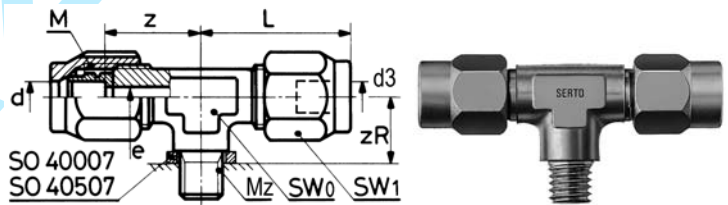

SO 43724 T

Type -d -Mz -d3	Mat.-Nr.	bar	M	SW0	SW1	L	zR	z	e	kg/100
Mz=metrisches Gewinde (zylindrisch)	Mz=Filetage métrique (cylindrique)		Mz=Metric thread (straight)							
SO 43724-2-M5-2	018.3743.050	125	6 x 0.75	7	8	16.5	8.5	12.5	2.2	1.210
SO 43724-3-M5-3	018.3743.055	125	6 x 0.75	7	8	18.0	8.5	13.0	2.2	1.290

Die entsprechende Dichtung ist immer separat zu bestellen. Weitere Einschraub-T siehe T-Verschraubung mit Übergangsnippel SO 43121.

Les joints correspondants sont à commander séparément. Autres Tés mâles voir Té avec adaptateur mâle SO 43121.

The relevant washer must always be ordered separately. Alternative male adaptor Tee see Tee union with male adaptor SO 43121.

d=Rohrassens-ø
e=kleinste Bohrung
L=Mass in montiertem Zustand
*=mit reduziertem Klemmring

d=ø extérieur du tube
e=ø-min. de passage
L=après montage
*=avec bague de serrage de réduction

d=tube outside diameter
e=minimum bore
L=installed length
*=with reduction compression ferrule

4M

L-Einschraubverschraubung

L mâle

Male adaptor L union

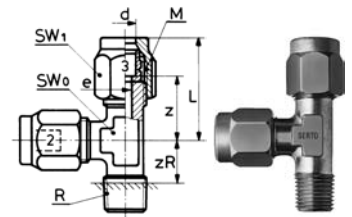

SO 43721 L

Type -R -d2 -d3	Mat.-Nr.	bar	M	SW0	SW1	L	zR	z	e	kg/100
Für metrische Rohre	Pour tubes métriques	For metric tubes								
* SO 43721-1/8-3-3	018.3711.030	125	8 x 1	7	10	22.5	10.5	16.0	3.0	2.410
SO 43721-1/8-4-4	018.3711.050	125	8 x 1	7	10	22.0	10.5	16.0	3.0	2.370
* SO 43721-1/4-1/4-4	018.3701.045	125	10 x 1	10	12	23.5	13.0	16.0	4.0	4.110
SO 43721-1/8-5-5	018.3711.070	125	8 x 1	7	10	22.5	10.5	16.0	3.0	2.350
* SO 43721-1/4-5-5	018.3711.160	125	10 x 1	10	12	23.5	13.0	16.0	4.0	4.130
SO 43721-1/8-6-6	018.3711.100	250	10 x 1	10	12	23.5	11.0	16.0	4.0	3.520
SO 43721-1/4-6-6	018.3711.180	250	10 x 1	10	12	23.5	13.0	18.0	4.0	4.070
SO 43721-1/4-8-8	018.3711.220	150	12 x 1	10	14	26.0	13.0	18.0	6.0	4.750
SO 43721-1/4-10-10	018.3711.260	125	14 x 1	14	17	30.5	15.5	20.5	8.0	7.040

Für Zollrohre	Pour tubes pouces	For inch tubes								
SO 43721-1/8-6,35-6,35	018.3711.110	100	10 x 1	10	12	23.5	11.0	16.0	4.0	3.490
SO 43721-1/4-6,35-6,35	018.3711.190	100	10 x 1	10	12	23.5	13.0	18.0	4.0	4.040
SO 43721-1/4-9,52-9,52	018.3711.240	64	14 x 1	14	17	30.5	15.5	20.5	8.0	7.160

Die entsprechende Dichtung ist immer separat zu bestellen. Weitere Einschraub-L siehe L-Verschraubung mit Übergangsnippel SO 43121.

Les joints correspondants sont à commander séparément. Autres Tés mâles voir Té avec adaptateur mâle SO 43121.

The relevant washer must always be ordered separately. Alternative male adaptor Tee see Tee union with male adaptor SO 43121.

L-Einschraubverschraubung

L mâle

Male adaptor L union

SO 43724 L

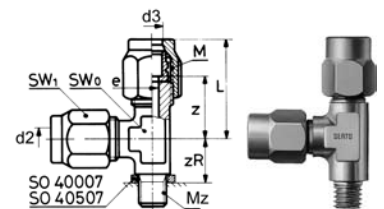

Type -Mz -d2 -d3	Mat.-Nr.	bar	M	SW0	SW1	L	zR	z	e	kg/100
Mz=metrisches Gewinde (zylindrisch)	Mz=Filetage métrique (cylindrique)	Mz=Metric thread (straight)								
SO 43724-M5-2-2	018.3753.050	125	6 x 0.75	7	8	16.5	8.5	12.5	2.2	1.180
SO 43724-M5-3-3	018.3753.055	125	6 x 0.75	7	8	18.0	8.5	13.0	2.2	1.260

Die entsprechende Dichtung ist immer separat zu bestellen. Weitere Einschraub-L siehe L-Verschraubung mit Übergangsnippel SO 43121.

Les joints correspondants sont à commander séparément. Autres Tés mâles voir Té avec adaptateur mâle SO 43121.

The relevant washer must always be ordered separately. Alternative male adaptor Tee see Tee union with male adaptor SO 43121.

d=Rohrassens-ø
e=kleinste Bohrung
L=Mass in montiertem Zustand
*=mit reduziertem Klemmring

d=ø extérieur du tube
e=ø-min. de passage
L=après montage
*=avec bague de serrage de réduction

d=tube outside diameter
e=minimum bore
L=installed length
*=with reduction compression ferrule

T-Schwenkverschraubung

Té banjo

Tee banjo

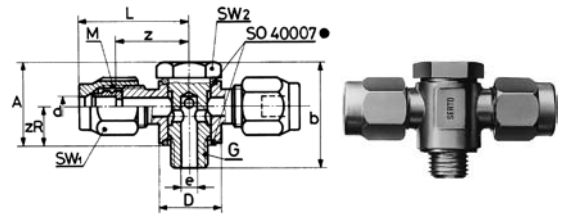

SO 43824

Type -d-G	Mat.-Nr.	bar	M	SW1	SW2	L	A	b	D	zR	z	e	kg/100
Für metrische Rohre G=Rohrgewinde (zylindrisch)	Pour tubes métriques G=Filetage-gaz BSP (cylindrique)	For metric tubes G=BSP thread (straight)											
* SO 43824-4-1/8	018.3841.060	125	10 x 1	12	14	25.0	20.0	28.0	15.0	9.5	17.5	3.8	4.130
* SO 43824-5-1/8	018.3841.082	125	10 x 1	12	14	25.0	20.0	28.0	15.0	9.5	17.5	3.8	4.410
SO 43824-6-1/8	018.3841.100	250	10 x 1	12	14	25.0	20.0	26.0	15.0	9.5	17.5	3.8	5.180
* SO 43824-6-1/4	018.3841.110	250	12 x 1	14	19	29.0	29.5	36.0	20.0	14.0	21.0	6.5	9.610
SO 43824-8-1/8	018.3841.160	150	12 x 1	14	14	25.5	22.5	28.0	15.0	10.5	17.5	3.8	5.970
SO 43824-8-1/4	018.3841.170	150	12 x 1	14	19	29.0	29.5	36.0	20.0	14.0	21.0	6.5	9.450
SO 43824-10-1/4	018.3841.270	125	14 x 1	17	19	31.0	29.0	36.0	20.0	13.5	21.0	6.5	11.110
Für Zollrohre	Pour tubes pouces	For inch tubes											
SO 43824-6,35-1/8	018.3841.135	100	10 x 1	12	14	25.0	20.0	28.0	15.0	9.5	17.5	3.8	5.150
SO 43824-9,52-1/4	018.3841.230	64	14 x 1	17	19	31.0	26.0	36.0	20.0	12.5	21.0	6.5	11.230

4M

T-Schwenkverschraubung METR

Té banjo METR

Tee banjo METR

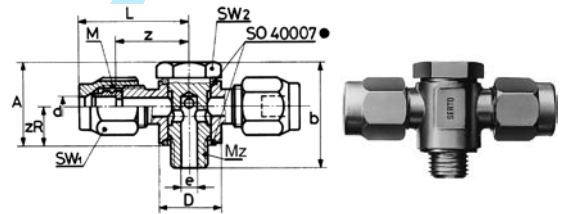

SO 43824 METR

Type -d-Mz	Mat.-Nr.	bar	M	SW1	SW2	L	A	b	D	zR	z	e	kg/100
Für metrische Rohre Mz=metrisches Gewinde (zylindrisch)	Pour tubes métriques Mz=Filetage métrique (cylindrique)	For metric tubes Mz=Metric thread (straight)											
* SO 43824-4-M10X1	018.3843.096	125	10 x 1	12	14	25.0	20.0	26.0	15.0	9.5	17.5	3.8	4.440
* SO 43824-5-M10X1	018.3843.135	125	10 x 1	12	14	25.0	20.0	26.0	15.0	9.5	17.5	3.8	4.430
SO 43824-6-M10X1	018.3843.180	250	10 x 1	12	14	25.0	20.0	26.0	15.0	9.5	17.7	3.8	5.240
* SO 43824-6-M12X1,5	018.3843.195	250	12 x 1	14	19	29.0	26.0	35.0	20.0	12.5	21.0	6.5	10.110
* SO 43824-6-M14X1,5	018.3843.198	250	12 x 1	14	19	29.0	26.0	35.0	20.0	12.5	21.0	6.5	10.070
SO 43824-8-M10X1	018.3843.230	150	12 x 1	14	14	25.5	20.0	26.0	15.0	9.5	21.0	6.5	6.050
SO 43824-8-M12X1,5	018.3843.240	150	12 x 1	14	19	29.0	26.0	35.0	20.0	12.5	21.0	6.5	9.790
SO 43824-8-M14X1,5	018.3843.245	150	12 x 1	14	19	29.0	26.0	35.0	20.0	12.5	21.0	6.5	9.750
SO 43824-10-M12X1,5	018.3843.275	125	14 x 1	17	19	31.0	26.0	35.0	20.0	12.5	21.0	6.5	11.460
SO 43824-10-M14X1,5	018.3843.280	125	14 x 1	17	19	31.0	26.0	35.0	20.0	12.5	21.0	6.5	11.420
Für Zollrohre	Pour tubes pouces	For inch tubes											
SO 43824-6,35-M10X1	018.3843.210	100	10 x 1	12	14	25.0	20.0	26.0	15.0	9.5	17.5	3.8	5.230
SO 43824-9,52-M12X1,5	018.3843.261	64	14 x 1	17	19	31.0	26.0	35.0	20.0	12.5	21.0	6.5	11.590
SO 43824-9,52-M14X1,5	018.3843.265	64	14 x 1	17	19	31.0	26.0	35.0	20.0	12.5	21.0	6.5	11.630

Dichtungen werden mitgeliefert.
Ersatzdichtungen siehe SO 40007.

Les joints sont fournis.
Joints de rechange voir SO 40007.

The gaskets are included.
Spare washers please see SO 40007.

d=Rohrassen-ø
e=kleinste Bohrung
L=Mass in montiertem Zustand
*=mit reduziertem Klemmring

d=ø extérieur du tube
e=ø-min. de passage
L=après montage
*=avec bague de serrage de réduction

d=tube outside diameter
e=minimum bore
L=installed length
*=with reduction compression ferrule

2-fach T-Schwenkverschraubung

Té banjo multiple

Tee double banjo

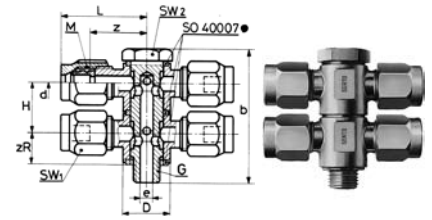

SO 43924

Type - n x d - G	Mat.-Nr.	bar	M	SW1	SW2	L	b	D	H	z	e	kg/100
Für metrische Rohre G=Rohrgewinde (zylindrisch)	Pour tubes métriques G=Filetage-gaz BSP (cylindrique)	For metric tubes G=BSP thread (straight)										
* SO 43924-2X4-1/8	018.3941.060	125	10 x 1	12	14	25.0	42.0	15.0	16.0	17.5	3.8	7.270
* SO 43924-2X5-1/8	018.3941.082	125	10 x 1	12	14	25.0	42.0	15.0	16.0	17.5	3.8	7.830
SO 43924-2X6-1/8	018.3941.100	250	10 x 1	12	14	25.0	42.0	15.0	16.0	17.5	3.8	9.370
* SO 43924-2X6-1/4	018.3941.110	250	12 x 1	14	19	29.0	56.0	20.0	21.0	21.0	6.5	17.270
SO 43924-2X8-1/8	018.3941.160	150	12 x 1	14	14	25.5	42.0	15.0	16.0	17.5	6.0	10.950
SO 43924-2X8-1/4	018.3941.170	150	12 x 1	14	19	29.0	56.0	20.0	21.0	21.0	6.5	16.950
SO 43924-2X10-1/4	018.3941.270	125	14 x 1	17	19	31.0	56.0	20.0	21.0	21.0	6.5	20.310
Für Zollrohre	Pour tubes pouces	For inch tubes										
SO 43924-2X6,35-1/8	018.3941.135	100	10 x 1	12	14	25.0	42.0	15.0	16.0	17.5	3.8	9.310
SO 43924-2X9,52-1/4	018.3941.230	64	14 x 1	17	19	31.0	56.0	20.0	21.0	21.0	6.5	20.550

Dichtungen werden mitgeliefert.
Ersatzdichtungen siehe SO 40007.

Les joints sont fournis.
Joints de rechange voir SO 40007.

The gaskets are included.
Spare washers please see SO 40007.

d=Rohraussen-ø
e=kleinste Bohrung
L=Mass in montiertem Zustand
*=mit reduziertem Klemmring

d=ø extérieur du tube
e=ø-min. de passage
L=après montage
*=avec bague de serrage de réduction

d=tube outside diameter
e=minimum bore
L=installed length
*=with reduction compression ferrule

Kreuzverschraubung

Croix

Cross union

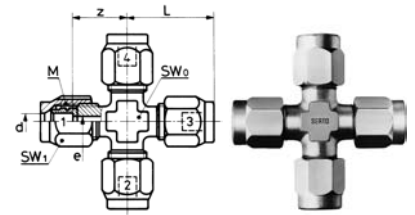

SO 44021

Type -d	Mat.-Nr.	bar	M	SW0	SW1	L	z	e	kg/100
Für metrische Rohre	Pour tubes métriques			For metric tubes					
* SO 44021-4	018.4000.040	125	8 x 1	10	10	25.5	19.5	3.5	4.800
SO 44021-5	018.4000.050	125	8 x 1	10	10	26.0	19.5	3.5	4.800
SO 44021-6	018.4000.060	250	10 x 1	10	12	25.5	18.0	4.0	6.030
SO 44021-8	018.4000.080	150	12 x 1	10	14	28.5	20.5	6.0	7.930
SO 44021-10	018.4000.100	125	14 x 1	14	17	30.5	20.5	8.0	11.880
SO 44021-12	018.4000.120	100	16 x 1	17	19	32.5	21.5	9.0	14.650
* SO 44021-13	018.4000.130	40	20 x 1.5	19	24	38.0	25.5	13.0	25.770
SO 44021-14	018.4000.140	40	20 x 1.5	19	24	38.0	25.5	13.0	26.620
SO 44021-15	018.4000.150	40	20 x 1.5	19	24	38.0	25.5	13.0	25.340
Für Zollrohre	Pour tubes pouces			For inch tubes					
SO 44021-6,35	018.4000.063	100	10 x 1	10	12	25.5	18.0	4.0	5.980
SO 44021-9,52	018.4000.095	64	14 x 1	14	17	30.5	20.5	8.0	12.120
* SO 44021-12,7	018.4000.127	40	20 x 1.5	19	24	38.0	25.5	13.0	25.770

4M

KONVEX

d=Rohrassens-ø
 e=kleinste Bohrung
 L=Mass in montiertem Zustand
 *=mit reduziertem Klemmring

d=ø extérieur du tube
 e=ø-min. de passage
 L=après montage
 *=avec bague de serrage de réduction

d=tube outside diameter
 e=minimum bore
 L=installed length
 *=with reduction compression ferrule

Schwenkverschraubung

mit Drossel-Ventil

Coude banjo

à passage réglable

Single banjo

with throttle valve

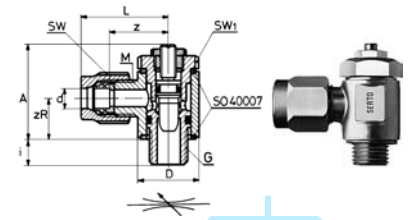

SO 47624

Type - d - G	Mat.-Nr.	bar	M	SW	SW1	L	z	zR	A	i	kv	kg/10
Für metrische Rohre G=Rohrgewinde (zylindrisch)	Pour tubes métriques G=Filetage-gaz BSP (cylindrique)	For metric tubes G=BSP thread (straight)										
SO 47624-3-1/8	028.7600.040	16	8 x 1	10	14	24.0	17.5	10.0	25.0	5.5	3.0	0.400
SO 47624-4-1/8	028.7600.060	16	8 x 1	10	14	23.5	17.5	10.0	25.0	5.5	3.0	0.380
SO 47624-5-1/8	028.7600.082	16	8 x 1	10	14	24.0	17.5	10.0	25.0	5.5	3.0	0.370
SO 47624-6-1/8	028.7600.100	16	10 x 1	12	14	25.0	17.5	10.0	25.0	5.5	3.0	0.430
* SO 47624-6-1/4	028.7600.110	16	12 x 1	14	19	29.0	21.0	14.0	25.0	6.5	6.0	0.860
SO 47624-8-1/8	028.7600.160	16	12 x 1	14	14	25.5	17.5	10.0	25.0	5.5	3.0	0.460
SO 47624-8-1/4	028.7600.170	16	12 x 1	14	19	29.0	21.0	14.0	30.5	6.5	6.0	0.840
SO 47624-10-1/4	028.7600.270	16	14 x 1	17	19	31.0	21.0	13.5	26.0	6.5	6.0	0.900
Für Zollrohre	Pour tubes pouces	For inch tubes										
SO 47624-6,35-1/8	028.7600.135	16	10 x 1	12	14	25.0	17.5	10.0	25.0	5.5	3.0	0.420
SO 47624-9,52-1/4	028.7600.230	16	14 x 1	17	19	31.0	21.0	13.5	26.0	6.5	6.0	0.910

Temperatur -20°C/+80°C

Température -20°C/+80°C

Temperature -20°C/+80°C

Dieses Drossel-Ventil dient zur Regulierung von Luftströmen in beiden Richtungen. Die Spindelfixierung mittels Kontermutter garantiert, dass sich die Spindel auch bei Vibration nicht verstellt.

Cet élément d'étanchéité sert au réglage de l'écoulement d'air dans les deux sens. La fixation de la broche à l'aide d'un contre-écrou garantit la stabilité du réglage même en cas de vibrations.

This throttle can be used for regulating air flow in both directions. The spindle fixture via counter-nut assures that spindle cannot shift, even due to vibration.

Technische Hinweise:

Körper, Ventileinsatz und Anschlüsse aus Messing. O-Ring aus NBR.

Données techniques:

Soupape, pointeau et écrous en laiton. Joint torique en matière NBR caoutchouc.

Technical notes:

Valve body, valve components and connections of brass. O-ring of NBR.

d=Rohrassen-ø

kv=Kenngröße für das Durchflussverhalten (litr./min)

L=Mass in montiertem Zustand

*=mit reduziertem Klemmring

d=ø extérieur du tube

kv=facteur d'écoulement (litr./min)

L=après montage

*=avec bague de serrage de réduction

d=tube outside diameter

kv=flow factor (litr./min)

L=installed length

*=with reduction compression ferrule

Schwenkverschraubung

mit Drosselrückschlag-Ventil

Coude banjo

à passage réglable et soupape de retenue

Single banjo

with throttle non-return valve

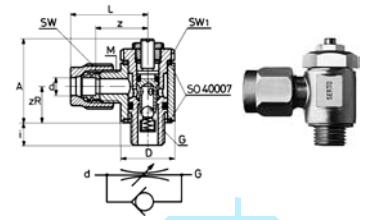

SO 47724

Type -d-G	Mat.-Nr.	bar	M	SW	SW1	L	A	D	i	zR	z	kv	kg/10
Für metrische Rohre G=Rohrgewinde (zylindrisch)	Pour tubes métriques G=Filetage-gaz BSP (cylindrique)	For metric tubes G=BSP thread (straight)											
* SO 47724-3-1/8	028.7700.040	16	8 x 1	10	14	24.0	25.0	15.0	5.5	10.0	17.5	3.0	0.400
SO 47724-4-1/8	028.7700.060	16	8 x 1	10	14	23.5	25.0	15.0	5.5	10.0	17.5	3.0	0.380
SO 47724-5-1/8	028.7700.082	16	8 x 1	10	14	24.0	25.0	15.0	5.5	10.0	17.5	3.0	0.370
SO 47724-6-1/8	028.7700.100	16	10 x 1	12	14	25.0	25.0	15.0	5.5	10.0	17.5	3.0	0.430
* SO 47724-6-1/4	028.7700.110	16	12 x 1	14	19	29.0	25.0	20.0	6.5	14.0	21.0	6.0	0.860
SO 47724-8-1/8	028.7700.160	16	12 x 1	14	14	25.5	25.0	15.0	5.5	10.0	17.5	3.0	0.460
SO 47724-8-1/4	028.7700.170	16	12 x 1	14	19	29.0	30.5	20.0	6.5	14.0	21.0	6.0	0.840
SO 47724-10-1/4	028.7700.270	16	14 x 1	17	19	31.0	26.0	20.0	6.5	14.0	21.0	6.0	0.900

Für Zollrohre	Pour tubes pouces	For inch tubes											
SO 47724-6,35-1/8	028.7700.135	16	10 x 1	12	14	25.0	25.0	15.0	5.5	10.0	17.5	3.0	0.420
SO 47724-9,52-1/4	028.7700.230	16	14 x 1	17	19	31.0	26.0	20.0	6.5	13.5	21.0	6.0	0.910

Temp: -20°C /+ 80°C Temp: -20°C/+ 80°C Temp: -20°C/+80°C

Dieses Drossel-Rückschlag-Ventil wird dort eingesetzt, wo unterschiedliche Geschwindigkeiten von Luftströmen benötigt werden. Die Spindelfixierung mittels Kontermutter garantiert, dass sich die Spindel auch bei Vibration nicht verstell.

Cet élément à passage réglable et soupape de retenue est utilisé lorsque les écoulements d'air doivent avoir une vitesse différente. La fixation de la broche à l'aide d'un contre-écrou garantit la stabilité du réglage même en cas de vibrations.

This non-return-throttle valve is installed where various air flow rates are required. The spindle fixture via counter-nut assures that spindle cannot shift, even due to vibration.

Technische Hinweise:
Körper, Ventileinsatz und Anschlüsse aus Messing, O-Ring aus NBR, Feder aus nichtrostendem Stahl, Kugel aus Polyurethan.

Données techniques:
Soupape, pointeau et écrous en laiton. Joint torique en matière NBR caoutchouc, ressort en acier inoxydable, bille en polyuréthane.

Technical notes:
Valve body, valve components and connections of brass, O-ring of NBR, spring of stainless steel, ball of polyurethane.

Schwenkverschraubungen siehe SO 42824, SO 42924, SO 43824 und SO 43924.

Coudes banjo voir SO 42824, SO 42924, SO 43824 et SO 43924.

Single banjo please see SO 42824, SO 42924, SO 43824 and SO 43924.

d=Rohrassen-ø d=ø extérieur du tube d=tube outside diameter
 kv=Kenngröße für das Durchflussverhalten (ltr./min) kv=facteur d'écoulement (ltr./min) kv=flow factor (ltr./min)
 L=Mass in montiertem Zustand L=après montage L=installed length
 *=mit reduziertem Klemmring *=avec bague de serrage de réduction *=with reduction compression ferrule

Anschlussvarianten mit Übergangsmuffe

Variantes de raccordement avec adaptateur femelle

Connections with female adaptor

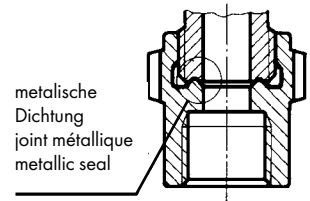

SO 40030

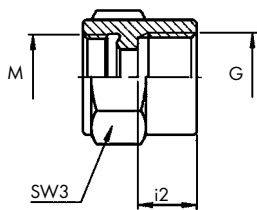

SO 42221



SO 43221



SO 44221

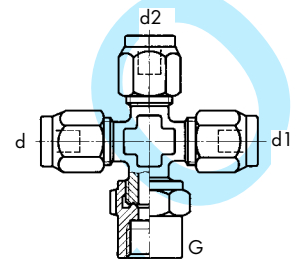

	SW3	-G	-d	-G	-d	-G	d3	-d	-G	d1	d2
M 10x1	14	-1/8			-4	-1/8	-4	-4	-1/8	-4	-4
M 10x1	17	-1/4			-4	-1/4	-4	-4	-1/4	-4	-4
M 10x1	22	-3/8			-4	-3/8	-4	-4	-3/8	-4	-4
M 10x1	14	-1/8			-5	-1/8	-5	-5	-1/8	-5	-5
M 10x1	17	-1/4			-5	-1/4	-5	-5	-1/4	-5	-5
M 10x1	22	-3/8			-5	-3/8	-5	-5	-3/8	-5	-5
M 10x1	14	-1/8			-6	-1/8	-6	-6	-1/8	-6	-6
M 10x1	17	-1/4			-6	-1/4	-6	-6	-1/4	-6	-6
M 10x1	22	-3/8			-6	-3/8	-6	-6	-3/8	-6	-6
M 12x1	17	-1/8			-8	-1/8	-8	-8	-1/8	-8	-8
M 12x1	17	-1/4			-8	-1/4	-8	-8	-1/4	-8	-8
M 12x1	22	-3/8			-8	-3/8	-8	-8	-3/8	-8	-8
M 14x1	17	-1/4			-10	-1/4	-10	-10	-1/4	-10	-10
M 14x1	22	-3/8			-10	-3/8	-10	-10	-3/8	-10	-10
M 16x1	27	-1/2			-10	-1/2	-10	-10	-1/2	-10	-10
M 16x1	19	-1/4			-12	-1/4	-12	-12	-1/4	-12	-12
M 16x1	22	-3/8			-12	-3/8	-12	-12	-3/8	-12	-12
M 16x1	27	-1/2			-12	-1/2	-12	-12	-1/2	-12	-12
M 20x1,5	32	-3/4	-12	-3/4	-12	-3/4	-12	-12	-3/4	-12	-12
M 20x1,5	24	-3/8	-13	-3/8	-13	-3/8	-13	-13	-3/8	-13	-13
M 20x1,5	27	-1/2			-13	-1/2	-13	-13	-1/2	-13	-13
M 20x1,5	32	-3/4	-13	-3/4	-13	-3/4	-13	-13	-3/4	-13	-13
M 20x1,5	24	-3/8	-14	-3/8	-14	-3/8	-14	-14	-3/8	-14	-14
M 20x1,5	27	-1/2			-14	-1/2	-14	-14	-1/2	-14	-14
M 20x1,5	32	-3/4	-14	-3/4	-14	-3/4	-14	-14	-3/4	-14	-14
M 20x1,5	24	-3/8	-15	-3/8	-15	-3/8	-15	-15	-3/8	-15	-15
M 20x1,5	27	-1/2			-15	-1/2	-15	-15	-1/2	-15	-15
M 20x1,5	32	-3/4	-15	-3/4	-15	-3/4	-15	-15	-3/4	-15	-15
M 24x1,5	30	-1/2			-16	-1/2	-16				
M 24x1,5	32	-3/4			-16	-3/4	-16				
M 24x1,5	30	-1/2			-17	-1/2	-17				
M 24x1,5	32	-3/4			-17	-3/4	-17				
M 24x1,5	30	-1/2			-18	-1/2	-18				
M 24x1,5	32	-3/4			-18	-3/4	-18				
M 28x1,5	36	-3/4			-19	-3/4	-19				
M 28x1,5	36	-3/4			-22	-3/4	-22				
M 36x2	41	-1	-28-1		-28	-1	-28				
M 42x2	50	-1 3/4	-35-1	-1 3/4	-35	-1 3/4	-35				
M 10x1	14	-1/8			-6,35	-1/8	-6,35	-6,35	-1/8	-6,35	-6,35
M 10x1	17	-1/4	-6,35	-1/4	-6,35	-1/4	-6,35	-6,35	-1/4	-6,35	-6,35
M 10x1	22	-3/8			-6,35	-3/8	-6,35	-6,35	-3/8	-6,35	-6,35
M 14x1,4	17	-1/4			-9,52	-1/4	-9,52	-9,52	-1/4	-9,52	-9,52
M 14x1,4	22	-3/8			-9,52	-3/8	-9,52	-9,52	-3/8	-9,52	-9,52
M 20x1,5	24	-3/8	-12,7	-3/8	-12,7	-3/8	-12,70	-12,7	-3/8	-12,70	-12,70
M 20x1,5		-1/2			-12,7	-1/2	-12,70	-12,7	-1/2	-12,70	-12,70
M 20x1,5	24	-3/4	-12,7	-3/4	-12,7	-3/4	-12,70	-12,7	-3/4	-12,70	-12,70

Anschlussvarianten mit Übergangsnippel

Variantes de raccordement avec adaptateur mâle

Connections with male adaptor

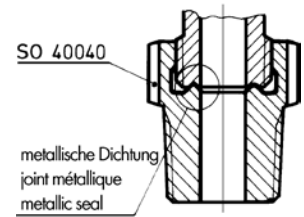

SO 40040

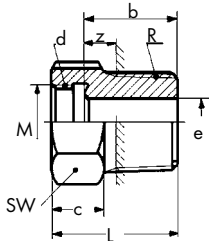

SO 42121



SO 43121



SO 44121

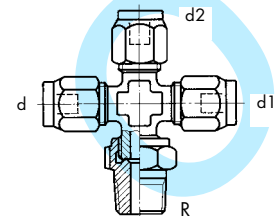

	SW3	-R	-d	-R	-d1	-R	d3	-d	-R	d1	d2
M 10x1	14	-1/8			-4	-1/8	-4	-4	-1/8	-4	-4
M 10x1	17	-3/8	-4	-3/8	-4	-3/8	-4				
M 10x1	17	-3/8	-5	-3/8	-5	-3/8	-5				
M 10x1	12	-1/8						-6	-1/8	-6	-6
M 10x1	14	-1/4						-6	-1/4	-6	-6
M 10x1	17	-3/8	-6	-3/8	-6	-3/8	-6	-6	-3/8	-6	-6
M 10x1	22	-1/2						-6	-1/2	-6	-6
M 12x1	14	-1/8						-8	-1/8	-8	-8
M 12x1	14	-1/4						-8	-1/4	-8	-8
M 12x1	17	-3/8			-8	-3/8	-8	-8	-3/8	-8	-8
M 14x1	17	-1/4						-10	-1/4	-10	-10
M 14x1	17	-3/8			-10	-3/8	-10	-10	-3/8	-10	-10
M 14x1	22	-1/2	-10	-1/2	-10	-1/2	-10	-10	-1/2	-10	-10
M 16x1	19	-1/4			-12	-1/4	-12	-12	-1/4	-12	-12
M 16x1	19	-3/8			-12	-3/8	-12	-12	-3/8	-12	-12
M 16x1	22	-1/2			-12	-1/2	-12	-12	-1/2	-12	-12
M 20x1,5	24	-3/8						-13	-3/8	-13	-13
M 20x1,5	24	-1/2			-13	-1/2	-13	-13	-1/2	-13	-13
M 20x1,5	27	-3/4	-13	-3/4	-13	-3/4	-13	-13	-3/4	-13	-13
M 20x1,5	24	-1/2			-14	-1/2	-14				
M 20x1,5	27	-3/4	-14	-3/4	-14	-3/4	-14				
M 20x1,5	24	-3/8						-15	-3/8	-15	-15
M 20x1,5	24	-1/2			-15	-1/2	-15	-15	-1/2	-15	-15
M 20x1,5	27	-3/4			-15	-3/4	-15	-15	-3/4	-15	-15
M 24x1,5	30	-1/2			-16	-1/2	-16				
M 24x1,5	30	-3/4			-16	-3/4	-16				
M 24x1,5	30	-1/2			-17	-1/2	-17				
M 24x1,5	30	-3/4			-17	-3/4	-17				
M 24x1,5	30	-1/2			-18	-1/2	-18				
M 24x1,5	30	-3/4			-18	-3/4	-18				
M 28x1,5	36	-3/4			-19	-3/4	-19				
M 28x1,5	36	-3/4			-22	-3/4	-22				
M 36x2	41	-1	-28	-1	-28	-1	-28				
M 42x2	50	-1 1/4	-35	-1 1/4	-35	-1 1/4	-35				
M 10x1	17	-3/8	-6,35	-3/8	-6,35	-3/8	-6,35	-6,35	-3/8	-6,35	-6,35
M 14x1		-3/8			-9,52	-3/8	-9,52	-9,52	-3/8	-9,52	-9,52
M 20x1,5	27	-1/2			-12,7	-1/2	-12,7	-12,7	-1/2	-12,7	-12,7
			-12,7	-3/4	-12,7	-3/4	-12,7	-12,7	-3/4	-12,7	-12,7

4M

Anschlussvarianten mit Übergangsnippel
Variantes de raccordement avec adaptateur mâle
Connections with female adaptor

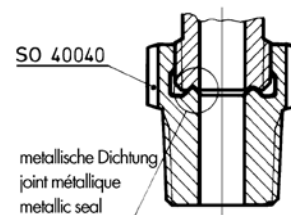

SO 40040

SO 42121

SO 43121

SO 44121

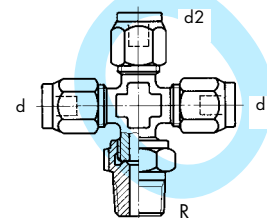
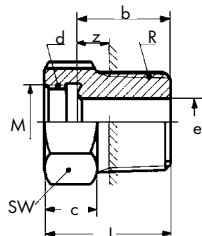

	SW	-R	-d	-R	-d1	-R	d3	-d	-R	d1	d2
M10x1	12	-1/8 NPT			-4	-1/8 NPT	-4	-4	-1/8 NPT	-4	-4
M10x1	14	-1/4 NPT	-4	-1/4 NPT	-4	-1/4 NPT	-4	-4	-1/4 NPT	-4	-4
M10x1	12	-1/8 NPT			-5	-1/8 NPT	-5	-5	-1/8 NPT	-5	-5
M10x1	14	-1/4 NPT	-5	-1/4 NPT	-5	-1/4 NPT	-5	-5	-1/4 NPT	-5	-5
M10x1	12	-1/8 NPT			-6	-1/8 NPT	-6	-6	-1/8 NPT	-6	-6
M10x1	14	-1/4 NPT			-6	-1/4 NPT	-6	-6	-1/4 NPT	-6	-6
M12x1	14	-1/8 NPT	-8	-1/8 NPT	-8	-1/8 NPT	-8	-8	-1/8 NPT	-8	-8
M12x1	14	-1/4 NPT			-8	-1/4 NPT	-8	-8	-1/4 NPT	-8	-8
M14x1	17	-1/4 NPT			-10	-1/4 NPT	-10	-10	-1/4 NPT	-10	-10
M10x1	14	-1/4 NPT	-6,35	-1/4 NPT	-6,35	-1/4 NPT	-6,35	-6,35	-1/4 NPT	-6,35	-6,35
M10x1	14	-1/8 NPT			-6,35	-1/8 NPT	-6,35	-6,35	-1/8 NPT	-6,35	-6,35
M14x1	17	-1/4 NPT			-9,52	-1/4 NPT	-9,52	-9,52	-1/4 NPT	-9,52	-9,52

Winkel-Einschraubverschraubung siehe auch SO 42421

Coude mâle voir aussi SO 42421

Male adaptor elbow union see also SO 42421

T-Einschraubverschraubung siehe auch SO 43721

Té mâle voir aussi SO 43721

Male adaptor tee union see also SO 43721

Messing M

Laiton M

Brass M

Rohrnippel

kurz

Mamelon

court

Double nipple

short

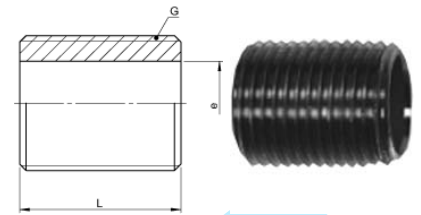

AD CNS 40

Type -G	Mat.-Nr.	L	e	kg/100
AD CNS 40-1/8	TAD.4180.042	20.0	6.5	0.480
AD CNS 40-1/4	TAD.4180.104	20.0	8.5	0.940
AD CNS 40-3/8	TAD.4180.166	20.0	11.0	1.490
AD CNS 40-1/2	TAD.4180.228	25.0	13.0	3.200
AD CNS 40-3/4	TAD.4180.292	26.0	19.0	4.670
AD CNS 40-1	TAD.4180.414	33.0	24.0	8.420

Aufschraub-Winkel

Coude double femelle

Female elbow

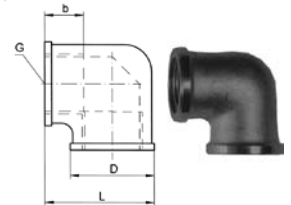

AD FE 40

Type -G	Mat.-Nr.	L	b	D	H	kg/100
AD FE 40-1/8	TAD.4300.042	21.0	9.0	15.0	15.0	2.000
AD FE 40-1/4	TAD.4300.104	30.0	11.0	22.0	18.0	4.380
AD FE 40-3/8	TAD.4300.166	36.0	12.0	23.0	23.0	5.930
AD FE 40-1/2	TAD.4300.228	39.0	15.0	27.0	25.0	7.430
AD FE 40-3/4	TAD.4300.292	46.0	15.0	36.0	33.0	12.090
AD FE 40-1	TAD.4300.414	57.0	17.0	42.0	38.0	21.100

Aufschraub-T

Té triple femelle

Female tee

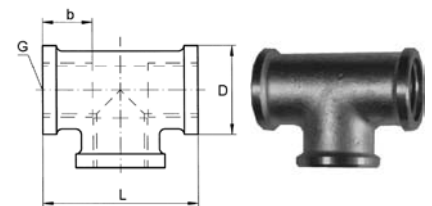

AD FT 40

Type -G	Mat.-Nr.	L	b	D	H	kg/100
AD FT 40-1/8	TAD.4400.060	28.0	9.0	15.0	14.0	2.610
AD FT 40-1/4	TAD.4400.160	40.0	11.0	21.0	20.0	5.680
AD FT 40-3/8	TAD.4400.350	48.0	12.0	23.0	24.0	9.360
AD FT 40-1/2	TAD.4400.450	52.0	14.0	27.0	26.0	9.700
AD FT 40-3/4	TAD.4400.520	60.0	15.0	36.0	30.0	16.760
AD FT 40-1	TAD.4400.650	67.0	17.0	42.0	33.5	25.850

4M

Messing M

Laiton M

Brass M

Sechskant-Muffe
Manchon double
Hex coupling

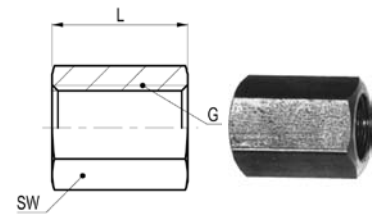

AD HC 40

Type -G	Mat.-Nr.	SW	L	kg/100
AD HC 40- $\frac{1}{8}$ - $\frac{1}{8}$	TAD.4100.042	14	22.0	1.240
AD HC 40- $\frac{1}{4}$ - $\frac{1}{4}$	TAD.4100.104	17	26.0	1.710
AD HC 40- $\frac{3}{8}$ - $\frac{3}{8}$	TAD.4100.166	22	19.0	3.090
AD HC 40- $\frac{1}{2}$ - $\frac{1}{2}$	TAD.4100.228	27	30.0	7.800
AD HC 40- $\frac{3}{4}$ - $\frac{3}{4}$	TAD.4100.292	32	36.0	11.170
AD HC 40-1 -1	TAD.4100.414	41	36.0	21.400

Sechskant-Muffe reduziert
Manchon double réduit
Hex reducing coupling

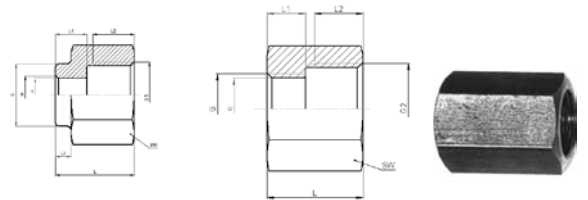

AD HRC 40

Type -G -G2	Mat.-Nr.	SW	L	L1	L2	e	kg/100
AD HRC 40- $\frac{1}{8}$ - $\frac{3}{8}$	TAD.4100.046	22	20.0	8.0	10.5	8.5	4.160
AD HRC 40- $\frac{1}{4}$ - $\frac{1}{2}$	TAD.4100.108	27	24.0	10.0	11.5	11.4	6.900
AD HRC 40- $\frac{1}{4}$ - $\frac{3}{4}$	TAD.4100.110	32	26.0	9.0	14.0	11.4	7.580
AD HRC 40- $\frac{1}{2}$ - $\frac{3}{4}$	TAD.4100.232	32	28.5	11.5	14.0	18.6	10.700
AD HRC 40- $\frac{1}{2}$ -1	TAD.4100.236	41	31.5	11.5	17.0	18.6	21.400

Rohrkappe
Capuchon femelle
Hex cap

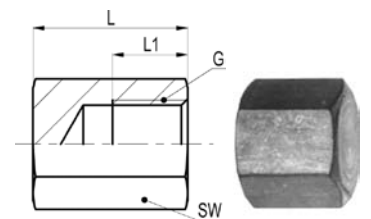

AD HCP 40

Type -G	Mat.-Nr.	SW	L	L1	kg/100
AD HCP 40- $\frac{1}{8}$	TAD.4000.020	14	10.0	8.0	0.980
AD HCP 40- $\frac{1}{4}$	TAD.4000.040	17	10.0	8.0	1.170
AD HCP 40- $\frac{3}{8}$	TAD.4000.060	19	10.0	8.0	3.460
AD HCP 40- $\frac{1}{2}$	TAD.4000.080	23	12.0	10.0	6.490
AD HCP 40- $\frac{3}{4}$	TAD.4000.120	30	14.5	12.0	11.490
AD HCP 40-1	TAD.4000.160	36	14.5	12.0	23.760

Doppelnippel Adaptateur mâle Male adaptor

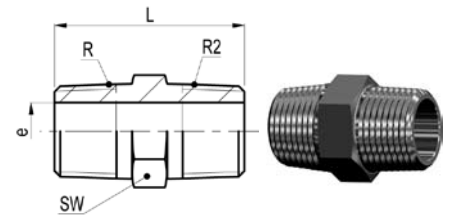

AD HN 40

Type -R -R2	Mat.-Nr.	SW	L	e	kg/100
AD HN 40- $\frac{1}{8}$ - $\frac{1}{8}$	TAD.4110.042	10	21.0	6.0	0.760
AD HN 40- $\frac{1}{8}$ - $\frac{1}{4}$	TAD.4110.044	14	26.0	6.0	1.200
AD HN 40- $\frac{1}{4}$ - $\frac{1}{4}$	TAD.4110.104	14	30.0	8.0	1.610
AD HN 40- $\frac{1}{4}$ - $\frac{3}{8}$	TAD.4110.106	14	31.0	8.0	2.010
AD HN 40- $\frac{1}{4}$ - $\frac{1}{2}$	TAD.4110.108	17	34.0	8.0	2.980
AD HN 40- $\frac{3}{8}$ - $\frac{3}{8}$	TAD.4110.166	17	30.0	10.0	3.240
AD HN 40- $\frac{3}{8}$ - $\frac{1}{2}$	TAD.4110.168	22	34.0	10.0	4.930
AD HN 40- $\frac{1}{2}$ - $\frac{1}{2}$	TAD.4110.228	22	36.0	14.0	5.420
AD HN 40- $\frac{1}{2}$ - $\frac{3}{4}$	TAD.4110.232	27	39.0	14.0	8.360
AD HN 40- $\frac{1}{2}$ -1	TAD.4110.236	36	45.0	14.0	15.240
AD HN 40- $\frac{3}{4}$ - $\frac{3}{4}$	TAD.4110.292	27	41.0	18.0	9.410
AD HN 40-1 -1	TAD.4110.414	36	51.0	24.0	17.760
AD HN 40- $\frac{1}{4}$ - $\frac{1}{4}$ NPT	TAD.4114.104	14	32.0	8.0	1.700

4M

6kt-Doppelnippel

beidseitig 60°-Innenkonus

Raccord six pans

à cône intérieur 60° des deux côtés

Hexagon barrel nipple

60° internal taper on both sides

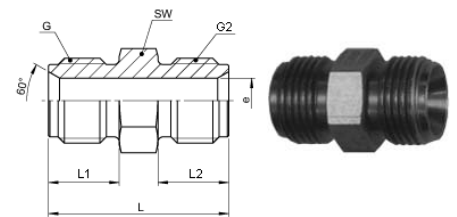

ADH HNC 40

Type -G -G2	Mat.-Nr.	SW	L	L1	L2	e	kg/100
ADH HNC 40- $\frac{1}{4}$	496.4100.104	14	26.0	10.0	10.0	7.5	1.690
ADH HNC 40- $\frac{1}{4}$ - $\frac{3}{8}$	496.4100.106	14	27.0	10.0	11.0	7.5	2.330
ADH HNC 40- $\frac{3}{8}$	496.4100.166	17	28.0	11.0	11.0	8.5	3.160

Verschlussstopfen 6kt

Bouchon mâle

Hex plug

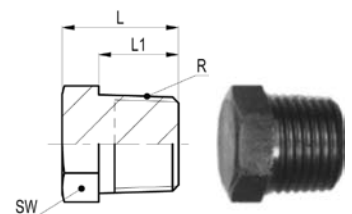

AD HP 40

Type -R	Mat.-Nr.	SW	L	L1	kg/100
AD HP 40- $\frac{1}{8}$	TAD.4020.020	12	13.0	8.0	0.970
AD HP 40- $\frac{1}{4}$	TAD.4020.040	14	18.0	12.0	2.060
AD HP 40- $\frac{3}{8}$	TAD.4020.060	17	19.0	12.0	3.460
AD HP 40- $\frac{1}{2}$	TAD.4020.080	22	22.0	14.0	6.490
AD HP 40- $\frac{3}{4}$	TAD.4020.120	27	25.0	16.0	11.490
AD HP 40-1	TAD.4020.160	36	31.0	20.0	23.760

Verschlussstopfen 6kt NPT

Bouchon mâle NPT

Hex plug NPT

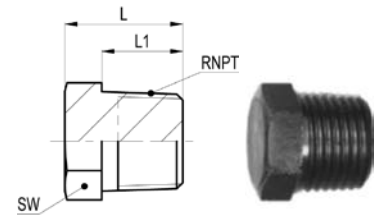

AD HP 40 NPT

Type -RNPT	Mat.-Nr.	SW	L	L1	kg/100
RNPT=NPT Gewinde	RNPT=Filetage NPT			RNPT=NPT thread	
AD HP 40-1/8 NPT	TAD.4021.020	12	15.0	10.0	1.130
AD HP 40-1/4 NPT	TAD.4021.040	14	20.0	14.0	2.320
AD HP 40-1/2 NPT	TAD.4021.080	22	27.0	19.0	7.720

Verschlusschraube mit O-Ring

Bouchon d'obturation avec joint torique

Screw plug with O-Ring

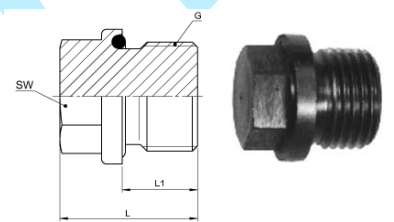

AD HPO 40

Type -G	Mat.-Nr.	SW	L	L1	kg/100
AD HPO 40-1/8	TAD.4040.020	10	17.0	8.0	1.200
AD HPO 40-1/4	TAD.4040.040	13	21.0	12.0	2.460
AD HPO 40-3/8	TAD.4040.060	17	21.0	12.0	4.800
AD HPO 40-1/2	TAD.4040.080	19	26.0	14.0	7.180
AD HPO 40-3/4	TAD.4040.120	24	30.0	16.0	13.040

Verschlusschraube mit Innen-6kt

Bouchon d'obturation

Screw Plug

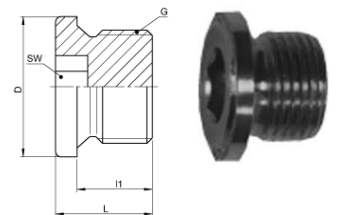

AD HSP 40

Type -G	Mat.-Nr.	SW	L	L1	D	kg/100
AD HSP 40-1/8	TAD.4070.020	5	11.0	8.0	14.0	0.610
AD HSP 40-1/4	TAD.4070.040	6	15.0	12.0	18.0	1.430
AD HSP 40-3/8	TAD.4070.060	8	15.0	12.0	22.0	2.240
AD HSP 40-1/2	TAD.4070.080	10	18.0	14.0	26.0	4.250
AD HSP 40-3/4	TAD.4070.120	12	20.0	16.0	32.0	7.410
AD HSP 40-1	TAD.4070.160	17	21.0	16.0	39.0	11.000

Verschlusschraube mit O-Ring
Bouchon d'obturation avec joint torique
Screw plug with O-Ring

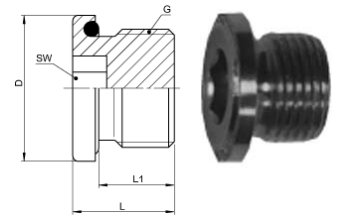
AD HSPO 40

Type -G	Mat.-Nr.	SW	L	L1	D	kg/100
AD HSPO 40-1/8	TAD.4050.020	5	11.0	8.0	14.0	0.610
AD HSPO 40-1/4	TAD.4050.040	6	15.0	12.0	18.0	1.430
AD HSPO 40-3/8	TAD.4050.060	8	15.0	12.0	22.0	2.240
AD HSPO 40-1/2	TAD.4050.080	10	18.0	14.0	26.0	4.250
AD HSPO 40-3/4	TAD.4050.120	12	20.0	15.0	32.0	7.410

Reduziermuffe
Manchon de réduction
Female reduction muff

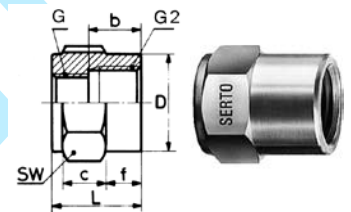

SO 40031

Type -G -G2	Mat.-Nr.	SW	L	b	f	D	kg/100
G=Rohrgewinde (zylindrisch)	G=Filetage-gaz BSP (cylindrique)	G=BSP thread (straight)					
G2=Rohrgewinde (zylindrisch)	G2=Filetage-gaz BSP (cylindrique)	G2=BSP thread (straight)					
SO 40031-1/8-1/8	016.0311.042	14	16.0	8.0	6.0	13.8	1.240
SO 40031-1/8-1/4	016.0311.044	17	19.0	11.0	8.0	16.8	2.170
SO 40031-1/8-3/8	016.0311.046	22	20.0	12.0	8.0	21.5	4.160
SO 40031-1/8-1/2	016.0311.048	27	22.0	14.0	8.0	26.5	6.940
SO 40031-1/4-1/4	016.0311.104	17	18.0	9.0	7.0	16.8	1.710
SO 40031-1/4-3/8	016.0311.106	22	21.0	12.0	9.0	21.8	4.060
SO 40031-1/4-1/2	016.0311.108	27	23.0	14.0	9.0	26.8	6.900
SO 40031-3/8-3/8	016.0311.166	22	19.0	9.5	7.0	21.8	3.090
SO 40031-3/8-1/2	016.0311.168	27	23.5	14.0	9.5	26.8	6.520
SO 40031-1/2-1/2	016.0311.228	27	23.0	11.5	9.0	26.8	5.450
SO 40031-3/4-3/8	016.0311.286	32	26.5	9.5	11.5	31.8	7.830
SO 40031-3/4-1/2	016.0311.288	32	28.5	11.5	13.5	31.8	9.870
SO 40031-3/4-3/4	016.0311.292	32	28.0	14.0	13.0	31.8	7.580

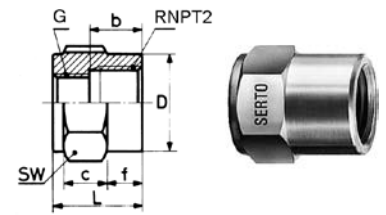
4M

Reduziermuffe NPT
Réduction femelle-femelle NPT
Female reduction muff NPT

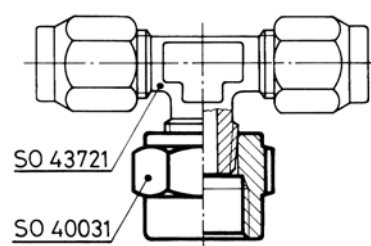
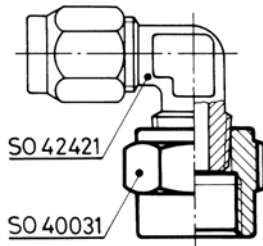
SO 40031 NPT

Type -G- RNPT2	Mat.-Nr.	SW	L	b	D	f	kg/100
G=Rohrgewinde (zylindrisch)	G=Filetage-gaz BSP (cylindrique)				G=BSP thread (straight)		
RNPT2=NPT Gewinde	RNPT2=Filetage NPT				RNPT2=NPT thread		
SO 40031-1/8-1/8 NPT	016.0312.042	14	20.0	10.0	13.8	10.0	1.340
SO 40031-1/8-1/4 NPT	016.0312.044	19	22.0	14.0	18.8	11.0	3.970
SO 40031-1/8-3/8 NPT	016.0312.046	22	22.0	14.0	21.8	11.0	4.260
SO 40031-1/4-1/8 NPT	016.0312.102	17	18.5	7.5	16.8	7.5	2.710
SO 40031-1/4-1/4 NPT	016.0312.104	19	25.0	14.0	18.8	14.0	4.300
SO 40031-1/4-3/8 NPT	016.0312.106	22	23.0	14.0	21.8	12.0	4.060
SO 40031-3/8-1/4 NPT	016.0312.164	22	21.0	9.0	21.8	9.0	3.670
SO 40031-3/8-3/8 NPT	016.0312.166	22	26.0	14.0	21.8	14.0	4.270
SO 40031-3/8-1/2 NPT	016.0312.168	27	28.0	18.0	26.8	14.0	6.870
SO 40031-1/2-1/4 NPT	016.0312.224	27	23.0	9.0	19.8	6.0	6.030
SO 40031-1/2-3/8 NPT	016.0312.226	27	24.0	10.0	26.8	10.0	6.520
SO 40031-1/2-1/2 NPT	016.0312.228	27	32.0	18.0	26.8	18.0	6.850

Anwendungsbeispiele:
Exemples d'utilisation:
Sample combinations:

Reduziernippel

Einschraubgewinde kegelig

Réduction femelle-mâle

Filetage conique

Male reduction nipple

Tapered adaptor thread

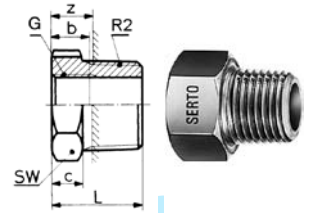

SO 40041 G R

Type -G-R2	Mat.-Nr.	SW	L	b	c	z	kg/100
G=Rohrgewinde (zylindrisch)	G=Filetage-gaz BSP (cylindrique)	G=BSP thread (straight)					
R2=Rohrgewinde (kegelig)	R2=Filetage-gaz BSP (conique)	R2=BSP thread (tapered)					
SO 40041-1/8-1/8	016.0411.042	14	21.0	8.0	13.0	14.5	2.100
SO 40041-1/8-1/4	016.0411.044	14	17.5	8.0	5.5	8.0	1.060
SO 40041-1/8-3/8	016.0411.046	17	18.0	8.0	6.0	8.0	2.280
SO 40041-1/8-1/2	016.0411.048	22	23.0	8.0	7.0	10.0	3.970
SO 40041-1/4-1/8	016.0411.102	17	22.0	9.0	13.0	15.5	1.630
SO 40041-1/4-3/8	016.0411.106	17	20.0	9.0	8.0	10.0	1.690
SO 40041-1/4-1/2	016.0411.108	22	23.0	9.0	7.0	10.0	3.590
SO 40041-1/4-3/4	016.0411.110	27	25.5	9.0	9.0	11.0	9.050
SO 40041-3/8-1/8	016.0411.162	22	23.0	9.5	16.0	16.5	3.490
SO 40041-3/8-1/4	016.0411.164	22	27.0	9.5	15.0	17.5	3.180
SO 40041-3/8-1/2	016.0411.168	22	23.0	9.5	10.0	10.0	2.740
SO 40041-3/8-3/4	016.0411.170	27	25.5	9.5	9.0	11.0	7.510
SO 40041-1/2-1/4	016.0411.224	27	29.0	11.5	17.0	19.0	5.852
SO 40041-1/2-3/8	016.0411.226	27	29.0	11.5	17.0	19.0	5.720
SO 40041-1/2-3/4	016.0411.232	27	27.5	11.5	9.0	13.0	5.133
SO 40041-1/2-1	016.0411.236	36	31.0	11.5	11.0	14.0	13.100
SO 40041-3/4-3/8	016.0411.286	32	33.5	14.0	21.5	23.5	8.900
SO 40041-3/4-1/2	016.0411.288	32	37.5	14.0	21.5	24.5	9.100
SO 40041-3/4-3/4	016.0411.292	32	38.0	14.0	21.5	23.5	9.400
SO 40041-3/4-1	016.0411.296	36	31.0	14.0	14.0	14.0	13.900
SO 40041-M5-1/8	016.0413.050	10	12.0	6.0	4.0	5.5	0.580

4M

Anwendungsbeispiele:

Exemples d'utilisation:

Sample combinations:

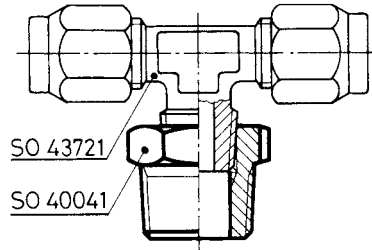
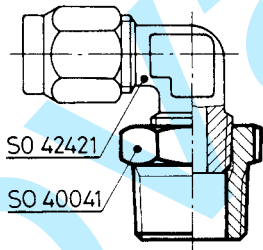

Reduziernippel G-NPT

Einschraubgewinde kegelig

Réduction femelle-mâle G-NPT

Filetage conique

Male reduction nipple G-NPT

Tapered adaptor thread

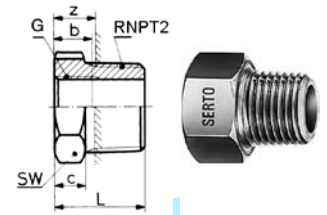

SO 40041 G NPT

Type -G -RNPT2	Mat.-Nr.	SW	L	b	c	z	kg/100
G=Rohrgewinde (zylindrisch)	G=Filetage-gaz BSP (cylindrique)					G=BSP thread (straight)	
RNPT2=NPT Gewinde	RNPT2=Filetage NPT					RNPT2=NPT thread	
SO 40041-1/8-1/8 NPT	016.0412.042	14	23.0	8.0	13.0	17.5	2.300
SO 40041-1/8-1/4 NPT	016.0412.044	14	20.0	8.0	6.0	10.0	1.200
SO 40041-1/4-1/8 NPT	016.0412.102	17	24.5	9.0	14.5	18.0	3.000
SO 40041-1/4-1/4 NPT	016.0412.104	17	26.5	9.0	14.5	16.5	3.900
SO 40041-1/4-3/8 NPT	016.0412.106	17	21.0	9.0	7.0	11.0	2.800
SO 40041-1/4-1/2 NPT	016.0412.108	22	27.0	9.0	8.0	13.5	7.700
SO 40041-3/8-1/4 NPT	016.0412.164	22	29.5	9.5	15.5	19.5	5.900
SO 40041-3/8-3/8 NPT	016.0412.166	22	29.5	9.5	15.5	19.5	6.800
SO 40041-3/8-1/2 NPT	016.0412.168	22	27.0	9.5	8.0	13.5	5.400
SO 40041-3/8-3/4 NPT	016.0412.170	27	29.0	9.5	9.0	15.0	12.800
SO 40041-1/2-1/2 NPT	016.0412.228	27	37.5	11.5	18.5	24.0	11.100
SO 40041-1/2-3/4 NPT	016.0412.232	27	31.0	11.5	11.0	17.0	8.900
SO 40041-3/4-3/4 NPT	016.0412.292	32	41.5	14.0	21.5	28.0	17.200
SO 40041-3/4-1 NPT	016.0412.296	36	33.0	14.0	11.0	16.0	16.500

Reduziernippel NPT-R

Einschraubgewinde kegelig

Réduction femelle-mâle NPT-R

Filetage conique

Male reduction nipple NPT-R

Tapered adaptor thread

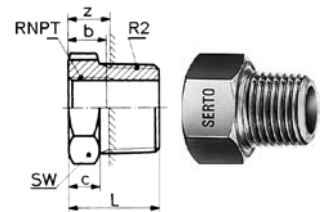

SO 40041 NPT R

Type -RNPT -R2	Mat.-Nr.	SW	L	b	c	z	kg/100
RNPT=NPT Gewinde	RNPT=Filetage NPT					RNPT=NPT thread	
R2=Rohrgewinde (kegelig)	R2=Filetage-gaz BSP (conique)					R2=BSP thread (tapered)	
SO 40041-1/8 NPT-1/8	016.0414.042	14	21.0	6.5	13.0	14.5	1.470
SO 40041-1/8 NPT-1/4	016.0414.044	14	18.0	6.6	6.0	8.0	1.130
SO 40041-1/4 NPT-1/4	016.0414.104	17	29.5	9.5	17.5	20.0	2.740
SO 40041-1/4 NPT-3/8	016.0414.106	17	19.0	9.5	7.0	9.0	1.650
SO 40041-1/2 NPT-1/2	016.0414.228	27	38.0	12.5	22.0	25.0	8.310

Reduziernippel NPT-NPT

Einschraubgewinde kegelig

Réduction femelle-mâle NPT-NPT

Filetage conique

Male reduction nipple NPT-NPT

Tapered adaptor thread

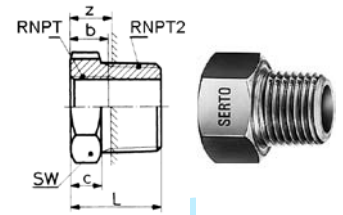

SO 40041 NPT NPT

Type -RNPT -RNPT2	Mat.-Nr.	SW	L	b	c	z	kg/100
RNPT=NPT Gewinde		RNPT=Filetage NPT			RNPT=NPT thread		
RNPT2=NPT Gewinde		RNPT2=Filetage NPT			RNPT2=NPT thread		
SO 40041-1/4 NPT 1/8 NPT	016.0415.102	17	27.5	9.5	17.5	21.0	2.450
SO 40041-1/4 NPT 1/4 NPT	016.0415.104	17	31.5	9.5	17.5	21.5	2.600
SO 40041-1/4 NPT 1/2 NPT	016.0415.108	22	27.0	9.5	8.0	13.5	5.200

Verschlusschraube

Bouchon d'obturation

Screw plug

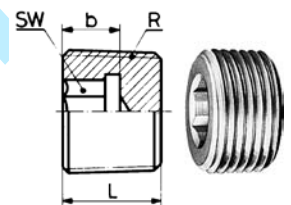

4M

SO 40371

Type -R	Mat.-Nr.	SW	L	b	kg/100
R=Rohrgewinde (kegelig)		R=Filetage-gaz BSP (conique)		R=BSP thread (tapered)	
SO 40371-1/8	016.0711.020	5	8.0	5.5	0.340
SO 40371-1/4	016.0711.040	7	10.0	7.5	0.750
SO 40371-3/8	016.0711.060	8	10.0	6.5	1.320
SO 40371-1/2	016.0711.080	10	10.0	6.5	1.940
SO 40371-3/4	016.0711.120	12	12.0	7.5	4.110

Einschraubtülle NPT

Douille cannelée à visser NPT

Male adaptor hose nipple NPT

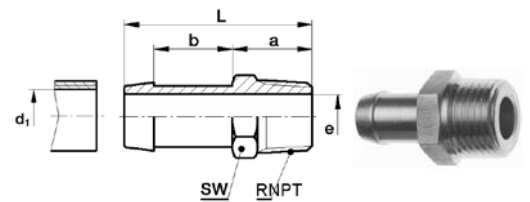

SO 40511 NPT

Type -d1 -RNPT	Mat.-Nr.	SW	L	a	b	e	kg/100
RNPT=NPT Gewinde		RNPT=Filetage NPT			RNPT=NPT thread		
SO 40511-6-1/4 NPT	016.0512.110	14	36.5	19.5	12.0	4.0	2.050
SO 40511-6-3/8 NPT	016.0512.120	17	37.0	20.0	12.0	4.0	3.150
SO 40511-8-1/8 NPT	016.0512.160	12	31.5	14.5	12.0	6.0	1.290

Einschraubtülle

Einschraubgewinde kegelig

Douille canellée a visser

Filetage conique

Male adaptor hose nipple

Tapered adaptor thread

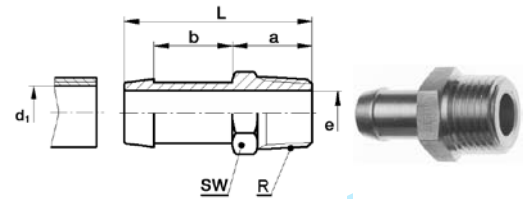

SO 40511

Type -d1 -R	Mat.-Nr.	SW	L	a	b	e	kg/100
R=Rohrgewinde (kegelig)	R=Filetage-gaz BSP (conique)					R=BSP thread (tapered)	
SO 40511-4-1/8	016.0511.060	10	23.0	12.0	8.0	3.0	0.750
SO 40511-6-1/8	016.0511.100	10	29.0	12.0	12.0	4.0	0.730
SO 40511-6-1/4	016.0511.110	14	34.5	17.5	12.0	4.0	1.920
SO 40511-8-1/8	016.0511.160	10	29.0	12.0	12.0	6.0	0.780
SO 40511-8-1/4	016.0511.170	14	34.5	17.5	12.0	6.0	1.690
SO 40511-8-3/8	016.0511.180	17	35.0	18.0	12.0	6.0	2.910
SO 40511-8-1/2	016.0511.185	22	40.0	23.0	12.0	6.0	4.530
SO 40511-10-1/8	016.0511.265	12	31.0	12.0	14.0	6.0	1.580
SO 40511-10-1/4	016.0511.270	14	36.5	17.5	14.0	7.0	1.640
SO 40511-10-3/8	016.0511.280	17	37.0	18.0	14.0	7.0	2.910
SO 40511-10-1/2	016.0511.285	22	42.0	23.0	14.0	7.0	4.900
SO 40511-13-3/8	016.0511.450	17	39.0	18.0	15.0	10.0	2.910
SO 40511-13-1/2	016.0511.454	22	44.0	23.0	15.0	10.0	5.340
SO 40511-16-1/2	016.0511.566	22	49.0	23.0	18.0	13.0	5.410
SO 40511-19-1/2	016.0511.676	22	49.0	23.0	18.0	15.0	5.800
SO 40511-19-3/4	016.0511.678	27	51.0	25.0	18.0	16.0	10.900

Schlauchklemme

Stahl promatverzinkt

Collier de serrage

Acier zingué passivé

Hose clip

Zinc promatised steel



SO 40512

Type -d	Mat.-Nr.	B	D	kg/100
SO 40512-3-5	016.0610.030	5.0	5.0	0.065
SO 40512-5-7	016.0610.050	3.0	7.0	0.100
SO 40512-7-9	016.0610.070	7.0	9.0	0.220
SO 40512-9-11	016.0610.090	7.0	11.0	0.245
SO 40512-11-13	016.0610.110	7.0	13.0	0.280
SO 40512-13-15	016.0610.130	7.5	15.0	0.385
SO 40512-15-18	016.0610.150	8.0	18.0	0.510
SO 40512-17-20	016.0610.170	8.5	20.0	0.585
SO 40512-20-23	016.0610.200	9.0	23.0	0.920
SO 40512-23-27	016.0610.230	10.0	27.0	1.200